

**QUICK SELECTION / Selezione veloce** The dynamic efficiency is **0.96** for all ratios **input speed (n<sub>1</sub>) = 1400 min<sup>-1</sup>**

Output Speed n <sub>2</sub> [min <sup>-1</sup> ]	Ratio i	Motor power P <sub>1M</sub> [kW]	Output torque M <sub>2M</sub> [Nm]	Service factor f.s.	Nominal power P <sub>1R</sub> [kW]	Nominal torque M <sub>2R</sub> [Nm]	Available B5 motor flanges					Available B14 motor flanges				Output Shaft 	Ratios code	
							-C	-D	-E	-F	-G	-R	-T	-U	-V			
							71	80	90	100 112	132	80	90	100 112	132			
232	<b>6.03</b>	5.5	211	1.1	<b>6.1</b>	<b>240</b>	B										3011	01
151	<b>9.26</b>	4	238	1.1	<b>4.5</b>	<b>270</b>	B										308	02
123	<b>11.36</b>	4	291	1.2	<b>4.7</b>	<b>350</b>	B										2011	03
91	<b>15.36</b>	4	394	1.0	<b>3.8</b>	<b>385</b>	B										1611	04
80	<b>17.46</b>	4	448	0.9	<b>3.5</b>	<b>400</b>	B										208	05
70	<b>19.97</b>	3	386	1.1	<b>3.1</b>	<b>410</b>	B										1311	06
59	<b>23.60</b>	3	456	0.9	<b>2.7</b>	<b>410</b>	B										168	07
57	<b>24.45</b>	3	472	0.9	<b>2.6</b>	<b>410</b>	B										1111	08
45.6	<b>30.69</b>	2.2	436	0.9	<b>2.0</b>	<b>410</b>	B										138	09
39.6	<b>35.35</b>	1.5	346	1.2	<b>1.8</b>	<b>410</b>	B										811	10
37.3	<b>37.57</b>	1.5	368	1.1	<b>1.7</b>	<b>410</b>	B										118	11
28.8	<b>48.68</b>	1.1	348	1.0	<b>1.1</b>	<b>365</b>	B										611	12
25.8	<b>54.33</b>	1.1	389	1.1	<b>1.2</b>	<b>410</b>	B										88	13
18.7	<b>74.81</b>	0.75	367	1.0	<b>0.73</b>	<b>360</b>	B										68	14

**A) Motor Flanges Available**  
Flange Motore Disponibili

**B) Supplied with Reduction Bushing**  
Fornito con Bussola di Riduzione

**B) Available on Request without reduction bushing**  
Disponibile a Richiesta senza Bussola di Riduzione

**C) Motor Flange Holes Position**  
Posizione Fori Flangia Motore

**EN** Unit **X62A** is supplied with synthetic oil for lifetime lubrication, no maintenance is necessary. See table 1 for lubrication and recommended quantity. In table 2 please see possible radial loads and axial loads on the gearbox.

**I** Il riduttore **X62A** viene fornito completo di olio sintetico per la lubrificazione permanente e non necessita di alcuna manutenzione. Vedi tab.1 per oli e quantità consigliati. In tab.2 sono presenti i carichi radiali e assiali applicabili al riduttore.

**D** Das Getriebe **X62A** ist mit synthetischem Öl gefüllt und ist lebensdauergeschmiert. In Tabelle 1 ist die Schmiermenge und das empfohlene Schmiermittel angegeben. In Tabelle 2 sind die zulässigen Radial - und Axialbelastungen des Getriebes aufgeführt.

**F** Le réducteur **X62A** est fourni complet avec de l'huile synthétique pour la lubrification permanente et ne nécessite aucun entretien. Voir tableau 1 concernant les huiles et les quantités conseillées. Les charges radiales et axiales applicables au réducteur sont précisées dans le tableau 2.

**E** El reductor tamaño **X62A** se suministra, lubricado de por vida con aceite sintético y no requieren mantenimiento alguna. Ver tabla 1, para cantidades y aceites recomendados. En la tabla 2, se encuentran las cargas radiales y axiales admitidas por el reductor.

Standard supplied	For these mounting position specify in the order or add oil Per queste posizioni specificare in fase d'ordine o aggiungere olio						
B3	B6	B7	B8	V5	V6	V8	
1.25 LT	1.70 LT	0.95 LT	1.60 LT	2.45 LT	1.50 LT	Ask	
<b>SHELL</b> Omala S4 WE 320				<b>ENI</b> Telium VSF 320			

For all details on lubrication and plugs check our website **tab. 1**  
Per maggiori dettagli su lubrificazione e tappi olio vedi il nostro sito web

### RADIAL AND AXIAL LOADS

**Output shaft**  
Albero di uscita

$$F_{eq} = F_R \cdot \frac{168}{X+138}$$

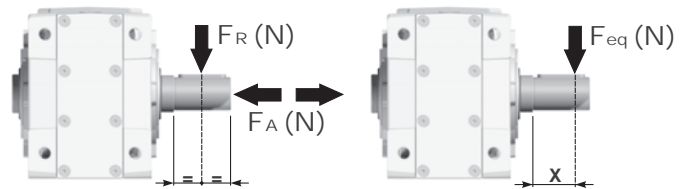

n <sub>2</sub> [min <sup>-1</sup> ]	FA	FR	n <sub>2</sub> [min <sup>-1</sup> ]	FA	FR	n <sub>2</sub> [min <sup>-1</sup> ]	FA	FR
250	600	3000	75	890	4450	15	1660	8300
150	700	3500	50	1140	5700			
100	780	3900	25	1330	6650			

**F<sub>R</sub>** On request taper roller bearings to increase radial loads.  
A richiesta cuscinetti a rulli conici per aumentare i carichi radiali.

**Input shaft**  
albero in entrata

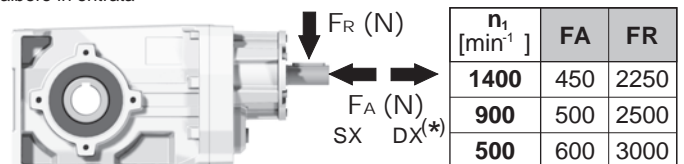

n <sub>1</sub> [min <sup>-1</sup> ]	FA	FR
1400	450	2250
900	500	2500
500	600	3000

**\*Strong axial loads in the DX direction are not allowed.**  
Non sono consentiti forti carichi assiali con direzione DX

**tab. 2**

**PX62AC...** Basic Gearbox  
Riduttore base

Gearbox weight  
peso riduttore **15.80 kg**

M. flanges	Kit code	øF	A
<b>71B5</b>	K023.4.041	160	253
<b>80/90B5</b>	K023.4.042	200	255
<b>100/112B5</b>	K023.4.043	250	264
<b>132B5</b>	KC51.4.043	300	285
<b>80B14</b>	K085.4.046	120	255
<b>90B14</b>	K085.4.045	140	255
<b>100/112B14</b>	K085.4.047	160	264
<b>132B14</b>	KC51.4.041	200	285

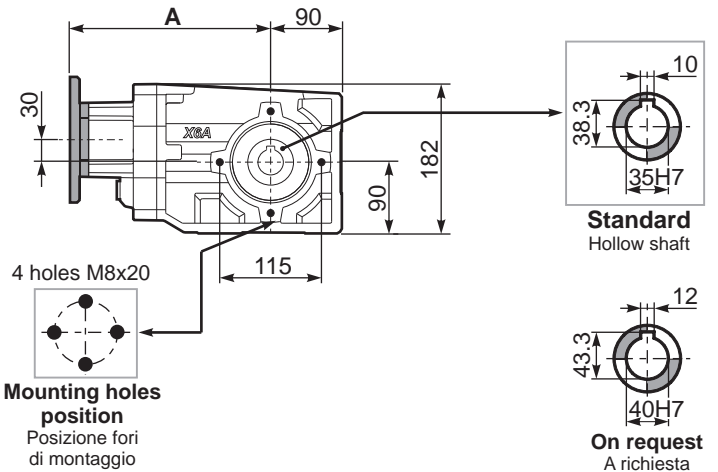
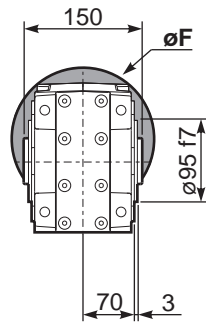

**PX62A...FB..** Feet  
Piedini

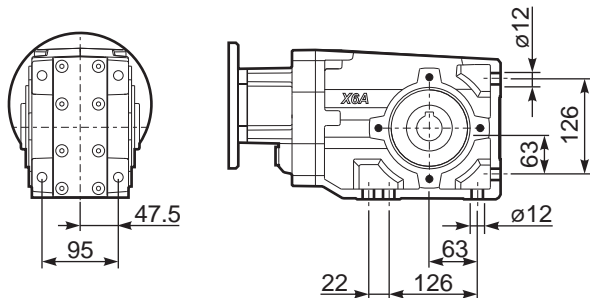

**PX62A...-F2..** Output flange  
Flangia uscita

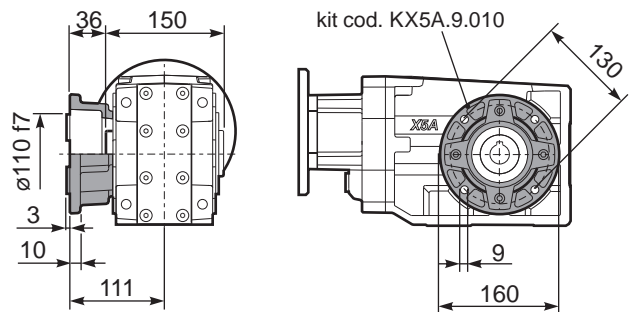

**PX62A...-F3..** Output flange  
Flangia uscita

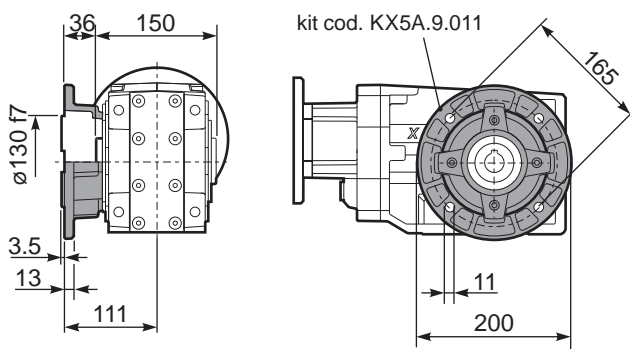

**PX62A...-F4..** Output flange  
Flangia uscita

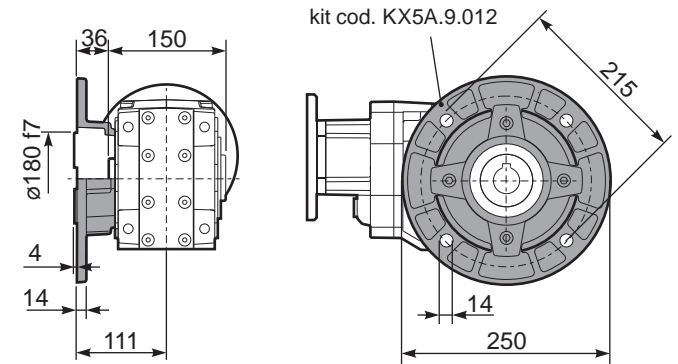

**RX62A...** Input shaft  
Albero in entrata

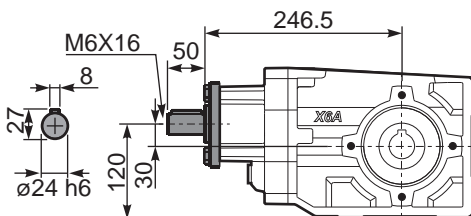

**PX62A...BR..** Reaction Arm  
Braccio di reazione

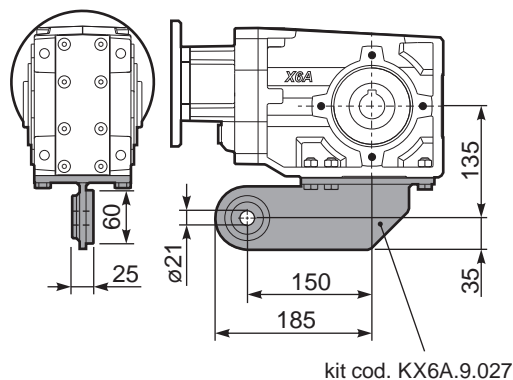

**PX62AA...** Single output shaft  
Albero semplice in uscita

