

**QUICK SELECTION / Selezione veloce** The dynamic efficiency is **0.96** for all ratios **input speed (n<sub>1</sub>) = 1400 min<sup>-1</sup>**

Output Speed n <sub>2</sub> [min <sup>-1</sup> ]	Ratio i	Motor power P <sub>1M</sub> [kW]	Output torque M <sub>2M</sub> [Nm]	Service factor f.s.	Nominal power P <sub>1R</sub> [kW]	Nominal torque M <sub>2R</sub> [Nm]	Available B5 motor flanges				Available B14 motor flanges			Output Shaft 	Ratios code	
							-B	-C	-D	-E	-Q	-R	-T			
							63	71	80	90	71	80	90			
191	7.33	1.5	72	1.0	1.5	70	B				C	C		289	standard ø20	01
125	11.22	1.1	80	1.1	1.2	85	B				C	C		287		02
106	13.26	1.1	95	0.9	0.98	85	B				C	C		199		03
91	15.37	1.1	110	0.8	0.89	90	B				C	C		179		04
78	18.04	0.75	89	1.0	0.76	90	B				C	C		159		05
69	20.30	0.75	100	0.9	0.68	90	B				C	C		197		06
65	21.54	0.75	106	0.9	0.64	90	B				C	C		139		07
59	23.53	0.55	85	1.1	0.58	90	B				C	C		177		08
51	27.62	0.55	100	0.9	0.50	90	B				C	C		157		09
47.6	29.40	0.55	106	0.8	0.47	90	B				C	C		109		On request
42.5	32.97	0.37	80	1.1	0.42	90	B				C	C		137	11	
36.5	38.37	0.37	93	1.0	0.36	90	B				C	C		99	12	
31.1	45.00	0.25	73	1.2	0.31	90	B				C	C		107	13	
27.6	50.67	0.25	83	1.1	0.27	90	B				C	C		79	14	
23.8	58.73	0.18	73	1.2	0.23	90	B				C	C		97	15	
18.1	77.55	0.18	97	0.9	0.18	90	B				C	C		77	16	

Motor Flanges Available Flange Motore Disponibili    
 B) Supplied with Reduction Bushing Fornito con Bussola di Riduzione    
 B) Available on Request without reduction bushing Disponibile a Richiesta senza Bussola di Riduzione    
 C) Motor Flange Holes Position Posizione Fori Flangia Motore

**EN** Unit **X32S** is supplied with synthetic oil for lifetime lubrication, no maintenance is necessary. See table 1 for lubrication and recommended quantity. In table 2 please see possible radial loads and axial loads on the gearbox.

**I** Il riduttore **X32S** viene fornito completo di olio sintetico per la lubrificazione permanente e non necessita di alcuna manutenzione. Vedi tab.1 per oli e quantità consigliati. In tab.2 sono presenti i carichi radiali e assiali applicabili al riduttore.

**D** Das Getriebe **X32S** ist mit synthetischem Öl gefüllt und ist lebensdauer geschmiert. In Tabelle 1 ist die Schmiermenge und das empfohlene Schmiermittel angegeben. In Tabelle 2 sind die zulässigen Radial - und Axialbelastungen des Getriebes aufgeführt.

**F** Le réducteur **X32S** est fourni complet avec de l'huile synthétique pour la lubrification permanente et ne nécessite aucun entretien. Voir tableau 1 concernant les huiles et les quantités conseillées. Les charges radiales et axiales applicables au réducteur sont précisées dans le tableau 2.

**E** El reductor tamaño **X32S** se suministra, lubricado de por vida con aceite sintético y no requieren mantenimiento alguna. Ver tabla 1, para cantidades y aceites recomendados. En la tabla 2, se encuentran las cargas radiales y axiales admitidas por el reductor.

Standard supplied	For these mounting position specify in the order or add oil Per queste posizioni specificare in fase d'ordine o aggiungere olio					
B3	B6	B7	B8	V5	V6	V8
0.40 LT	0.60 LT	0.40 LT	0.60 LT	0.85 LT	0.60 LT	Ask
SHELL Omala S4 WE 320				ENI Telium VSF 320		

For all details on lubrication and plugs check our website **tab. 1**  
Per maggiori dettagli su lubrificazione e tappi olio vedi il nostro sito web

### • RADIAL AND AXIAL LOADS

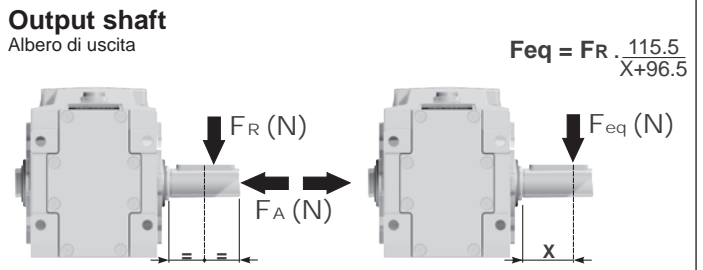

n <sub>2</sub> [min <sup>-1</sup> ]	FA	FR	n <sub>2</sub> [min <sup>-1</sup> ]	FA	FR	n <sub>2</sub> [min <sup>-1</sup> ]	FA	FR
250	400	2000	75	560	2800	15	560	2800
150	450	2250	50	560	2800			
100	500	2500	25	560	2800			

**F<sub>R</sub>** On request taper roller bearings to increase radial loads.  
A richiesta cuscinetti a rulli conici per aumentare i carichi radiali.

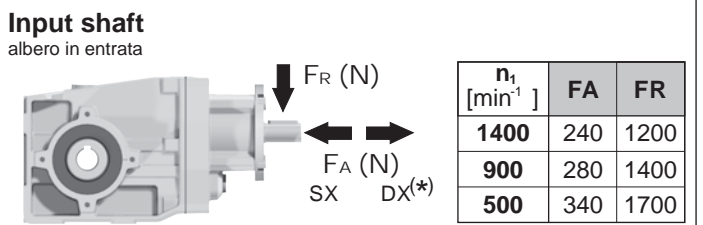

\*Strong axial loads in the DX direction are not allowed.  
Non sono consentiti forti carichi assiali con direzione DX

**tab. 2**

**PX32SC...** Basic Gearbox  
Riduttore base

Gearbox weight **6.30 kg**  
peso riduttore

M. flanges	Kit code	øF	A
63B5	K063.4.041	140	184
71B5	K063.4.042	160	182
80/90B5	K063.4.043	200	184
71B14	K063.4.047	105	182
80B14	K063.4.046	120	184
90B14	K063.4.041	140	184

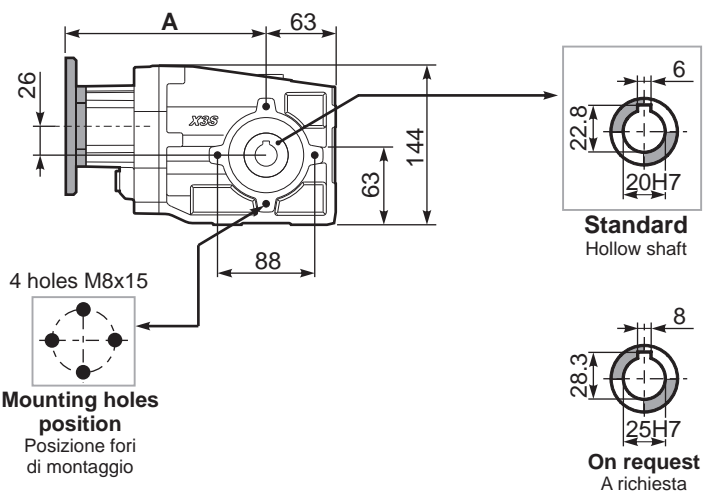
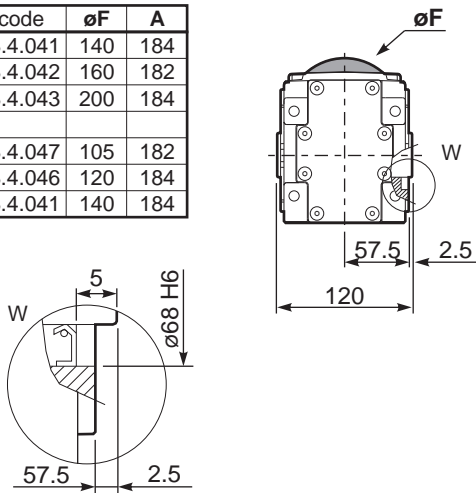

**PX32S...FB..** Feet  
Piedini

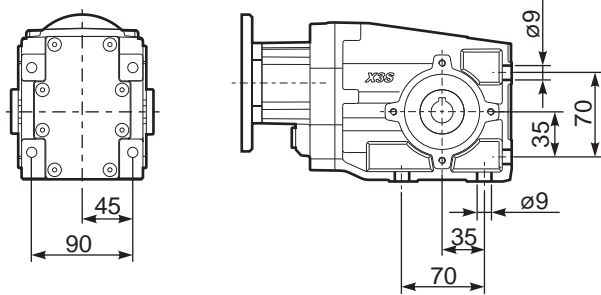

**PX32S...-F1..** Output flange  
Flangia uscita

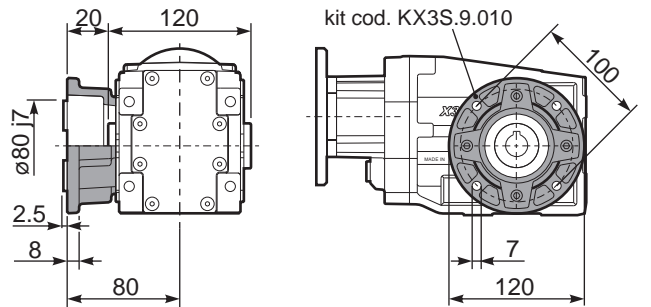

**PX32S...-F2..** Output flange  
Flangia uscita

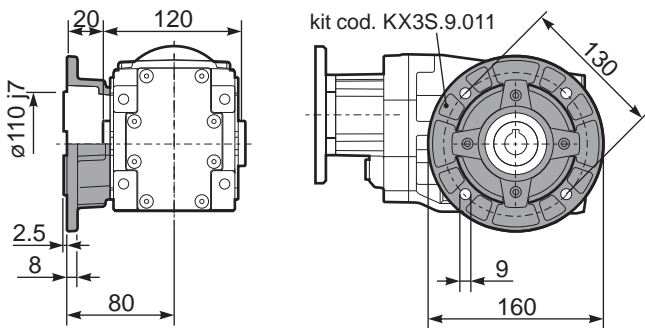

**PX32S...BR..** Reaction Arm  
Braccio di reazione

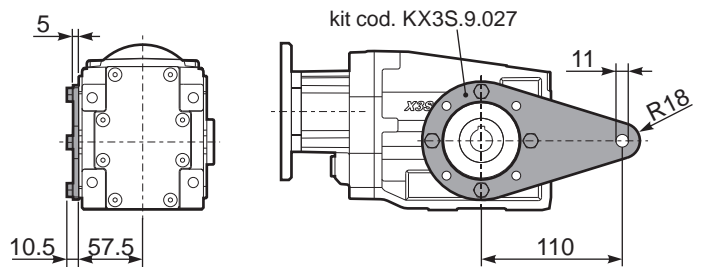

**RX32S...** Input shaft  
Albero in entrata

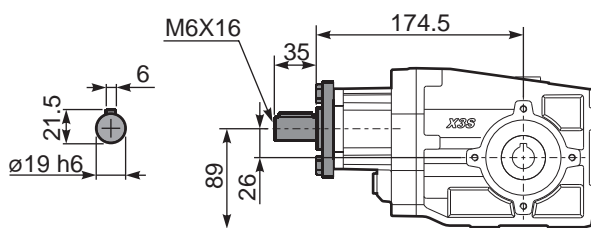

**PX32SA..** Single output shaft  
Albero semplice in uscita

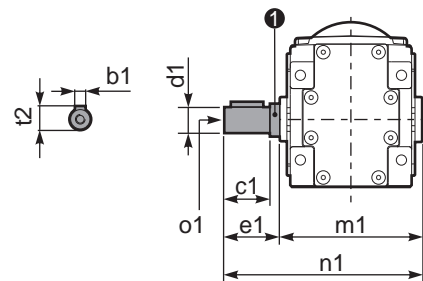

d1	b1	c1	e1	m1	n1	t2	o1	① kit code
ø20 k6	6	37.5	40	120	160	22.5	M8x20	KX2S.5.028
ø25 <sup>-0.005</sup> <sub>-0.020</sub>	8	60	63.2	126.8	190	28	M8x20	K063.5.028