

QUICK SELECTION / Selezione veloce

input speed (n_1) = 1400 min⁻¹

Output Speed n_2 [min ⁻¹]	Ratio i	Motor power P_{1M} [kW]	Output torque M_{2M} [Nm]	Service factor f.s.	Nominal power P_{1R} [kW]	Nominal torque M_{2R} [Nm]	Available B5 motor flanges				Available B14 motor flanges			Output Shaft 	Ratios code
							-B	-C	-D	-E	-Q	-R	-T		
							63	71	80	90	71	80	90		
15.3	91.23	1.5	858	1.2	1.7	1000	B				C	C		19132418	01
13.4	104.48	1.5	983	1.0	1.5	1000	B				C	C		19132416	02
11.6	121.10	1.5	1139	0.9	1.3	1000	B				C	C		17132416	03
9.9	140.84	1.1	968	1.0	1.1	1000	B				C	C		17132414	04
8.5	165.32	1.1	1136	0.9	0.96	1000	B				C	C		15132414	05
7.6	184.94	0.75	872	1.1	0.86	1000	B				C	C		19082416	06
7.1	197.34	0.75	930	1.1	0.81	1000	B				C	C		13132414	07
6.5	215.10	0.75	1014	1.0	0.74	1000	B				C	C		19082414	08
6.0	231.60	0.55	805	1.2	0.69	1000	B				C	C		10132416	09
5.6	249.31	0.55	867	1.2	0.64	1000	B				C	C		17082414	10
5.2	269.37	0.55	937	1.1	0.59	1000	B				C	C		10132414	11
4.8	292.64	0.55	1018	1.0	0.54	1000	B				C	C		15082414	12
4.6	302.26	0.55	1051	1.0	0.53	1000	B				C	C		9132416	13
4.0	349.30	0.37	812	1.2	0.46	1000	B				C	C		13082414	14
3.5	399.12	0.37	928	1.1	0.40	1000	B				C	C		7132416	15
2.9	476.80	0.37	1108	0.9	0.33	1000	B				C	C		10082414	16
2.2	622.28	0.25	976	1.0	0.26	1000	B				C	C		9082414	17
1.7	821.70	0.18	985	1.0	0.19	1000	B				C	C		7082414	18

The dynamic efficiency is **0.92** for all ratios

Motor Flanges Available
Flange Motore Disponibili

Supplied with Reduction Bushing
Fornito con Bussola di Riduzione

Available on Request without reduction bushing
Disponibile a Richiesta senza Bussola di Riduzione

Motor Flange Holes Position
Posizione Fori Flangia Motore

EN Unit **134C** is supplied without lubricant and equipped with a breather, level and drain plugs. User can add mineral oil keeping existing plugs. Should the user wish to fill it with synthetic oil, it is recommended to replace the existing plugs with a closed plug.
See table 1 for lubrication and recommended quantity.
In table 2 please see possible radial loads and axial loads on the gearbox.

B3	B6	B7	B8	V5	V6	V8
6.10 LT	4.40 LT	4.40 LT	3.40 LT	7.50 LT	3.20 LT	Ask
SHELL Omala S2 GX 460				ENI Blasias 460		

For all details on lubrication and plugs check our website **tab. 1**
Per maggiori dettagli su lubrificazione e tappi olio vedi il nostro sito web

I Il riduttore tipo **134C** è fornito privo di lubrificazione con tappi di sfiato, livello e scarico olio. L'utente può immettere olio minerale mantenendo i tappi esistenti. Se immetterà olio sintetico, dovrà sostituire i tappi esistenti con altri tipo chiuso.
Tab.1 per oli e quantità consigliati.
Tab.2 carichi radiali e assiali applicabili al riduttore.

D Das Getriebe der Baugröße **134C** wird ohne Schmiermittel geliefert. Es ist jedoch mit Einfüllschraube, Überdruckventil und Ablassschraube ausgerüstet. Das benötigte mineralische Öl kann über die Einfüllschraube eingefüllt werden. Sollte synthetisches Öl bevorzugt werden, so ist sind das eingebaute Überdruckventil durch eine geschlossenen Schraube zu ersetzen.
In Tabelle 1 ist die Schmiermenge und das empfohlene Schmiermittel angegeben.
In Tabelle 2 sind die zulässigen Radial - und Axialbelastungen des Getriebes aufgeführt.

F Le réducteur de type **134C** est fourni sans lubrification et avec un bouchon de remplissage, de niveau et d'évacuation de l'huile. L'utilisateur peut verser de l'huile minérale en conservant les bouchons existants.
S'il y versera de l'huile synthétique, il devra substituer les bouchons existants avec d'autres bouchons de type fermé.
Voir tableau 1 concernant les huiles et les quantités conseillées.
Voir tableau 2 concernant les charges radiales et axiales applicables au réducteur

E El reductor tamaño **134C** se suministra sin lubricante, provisto de tapones de respiración, nivel y descarga de aceite. El usuario puede utilizar aceite mineral, manteniendo los tapones existentes. Si prefiere utilizar aceite sintético deberá sustituir los tapones existentes por tapones ciegos. La prerreducción se suministra con tapones ciegos, lubricado de por vida con aceite sintético.
Ver tabla 1, para cantidades y aceites recomendados. En la tabla 2, se encuentran las cargas radiales y axiales admitidas por el reductor.

RADIAL AND AXIAL LOADS

Output shaft
Albero di uscita

$F_R(N)$

$F_{eq}(N)$ $F_{eq} = FR \cdot \frac{184.5}{X+144.5}$

n_2	F_A	F_R	n_2	F_A	F_R	n_2	F_A	F_R
300	800	4000	140	1120	5600	70	1400	7000
250	900	4500	120	1200	6000	40	1700	8500
200	960	4800	85	1300	6500	15	2400	12000

On request reinforced bearings to increase loads.
A richiesta cuscinetti rinforzati per aumentare i carichi.

Input shaft
Albero in entrata

$F_R(N)$ $F_A(N)$

n_1	F_A	F_R
1400	400	2000
900	440	2200
500	440	2200

tab. 2

P134CC... Basic gearbox
Riduttore base

Gearbox weight **53.5 kg**
peso riduttore

M. flanges	Kit code	øF	A
63B5	K063.4.041	140	263
71B5	K063.4.042	160	261
80/90B5	K063.4.043	200	263
71B14	K063.4.047	105	261
80B14	K063.4.046	120	263
90B14	K063.4.041	140	263

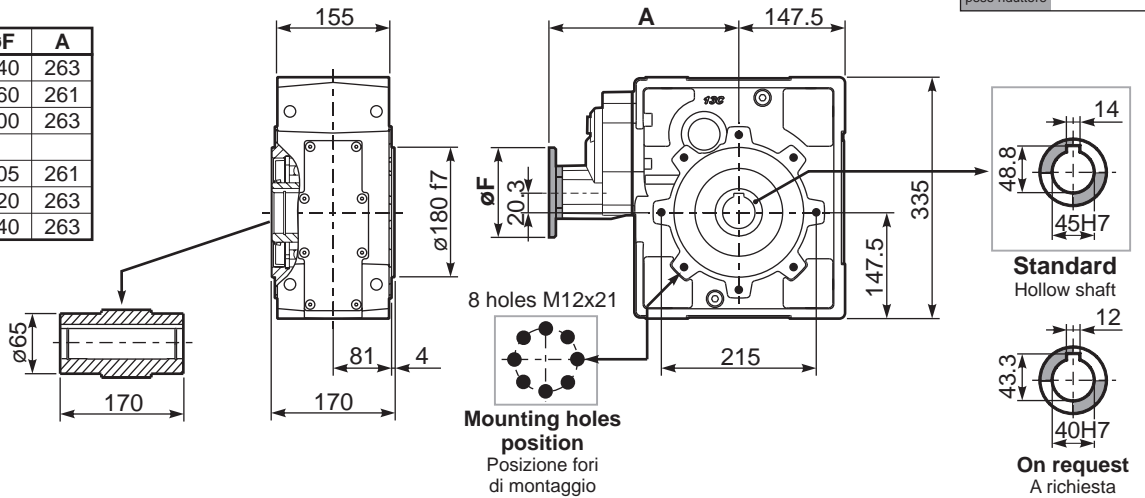

P134C...FB... Feet
Piedini

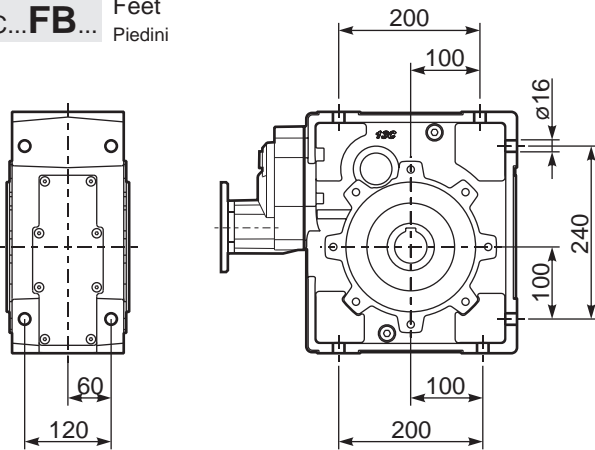

P134C...-FC... Output flange
Flangia uscita

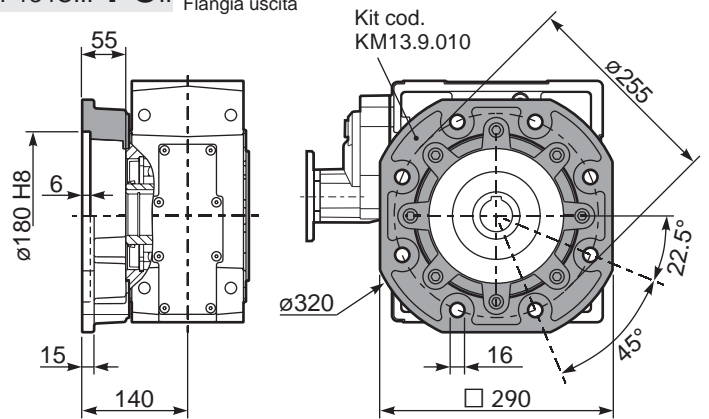

R134C... Input Shaft
Albero in entrata

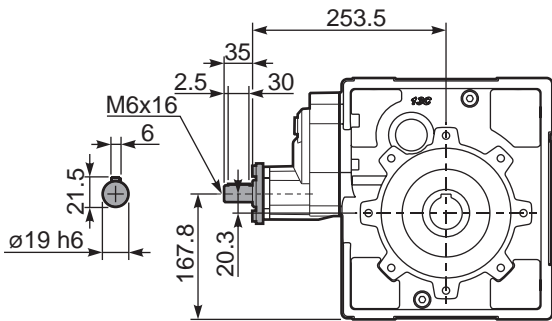

P134C...BR... Reaction arm
Braccio di reazione

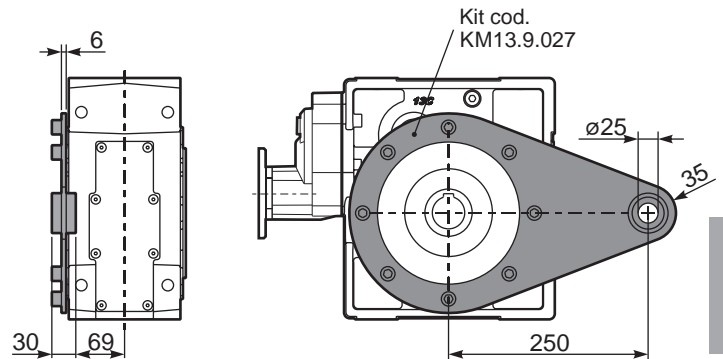

P134CA... Single output Shaft
Albero lento semplice

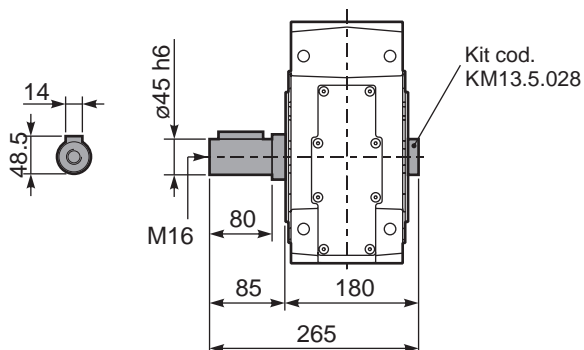

P134CB... Double Input Shaft
Albero lento bisporgente

