

### QUICK SELECTION / Selezione veloce

input speed (n<sub>1</sub>) = 1400 min<sup>-1</sup>

Output Speed n <sub>2</sub> [min <sup>-1</sup> ]	Ratio i	Motor power P <sub>1M</sub> [kW]	Output torque M <sub>2M</sub> [Nm]	Service factor f.s.	Nominal power P <sub>1R</sub> [kW]	Nominal torque M <sub>2R</sub> [Nm]	Available B5 motor flanges				Available B14 motor flanges			Output Shaft $\varnothing$ Ratios code	
							-B	-C	-D	-E	-Q	-R	-T		
							63	71	80	90	71	80	90		
18.7	<b>74.79</b>	1.5	704	1.0	1.4	675	B				C	C		19132418	01
16.3	<b>85.99</b>	1.1	591	1.1	1.3	675	B				C	C		19132416	02
14.0	<b>99.66</b>	1.1	685	1.0	1.1	675	B				C	C		17132416	03
12.0	<b>116.35</b>	0.75	548	1.2	0.92	675	B				C	C		17132414	04
11.5	<b>121.45</b>	0.75	572	1.2	0.89	675	B				C	C		13132418	05
10.0	<b>139.64</b>	0.75	658	1.0	0.77	675	B				C	C		13132416	06
9.2	<b>152.21</b>	0.75	717	0.9	0.71	675	B				C	C		19082416	07
8.6	<b>163.02</b>	0.55	567	1.2	0.66	675	B				C	C		13132414	08
7.9	<b>177.69</b>	0.55	618	1.1	0.61	675	B				C	C		19082414	09
6.8	<b>205.95</b>	0.55	716	0.9	0.52	675	B				C	C		17082414	10
6.3	<b>222.52</b>	0.55	774	0.9	0.48	675	B				C	C		10132414	11
5.6	<b>248.76</b>	0.37	578	1.2	0.43	675	B				C	C		9132416	12
4.8	<b>290.41</b>	0.37	675	1.0	0.37	675	B				C	C		9132414	13
4.1	<b>337.39</b>	0.37	784	0.9	0.32	675	B				C	C		10082416	14
3.6	<b>393.88</b>	0.25	618	1.1	0.27	675	B				C	C		10082414	15
3.2	<b>440.33</b>	0.25	690	1.0	0.24	675	B				C	C		9082416	16
2.7	<b>514.06</b>	0.18	616	1.1	0.21	675	B				C	C		9082414	17
2.4	<b>581.44</b>	0.18	697	1.0	0.18	675	B				C	C		7082416	18
2.1	<b>678.79</b>	0.12	526	1.3	0.16	675	B				C	C		7082414	19

The dynamic efficiency is **0.92** for all ratios

**A** Motor Flanges Available  
Flange Motore Disponibili

**B** Supplied with Reduction Bushing  
Fornito con Bussola di Riduzione

**B** Available on Request without reduction bushing  
Disponibile a Richiesta senza Bussola di Riduzione



**C** Motor Flange Holes Position  
Posizione Fori Flangia Motore

**EN** Unit **114C** is supplied with synthetic oil for lifetime lubrication, no maintenance is necessary. See table 1 for lubrication and recommended quantity. In table 2 please see possible radial loads and axial loads on the gearbox.

**I** Il riduttore **114C** viene fornito completo di olio sintetico per la lubrificazione permanente e non necessita di alcuna manutenzione. Vedi tab.1 per oli e quantità consigliati. In tab.2 sono presenti i carichi radiali e assiali applicabili al riduttore.

**D** Das Getriebe **114C** ist mit synthetischem Öl gefüllt und ist lebensdauer geschmiert. In Tabelle 1 ist die Schmiermenge und das empfohlene Schmiermittel angegeben. In Tabelle 2 sind die zulässigen Radial - und Axialbelastungen des Getriebes aufgeführt.

**F** Le réducteur **114C** est fourni complet avec de l'huile synthétique pour la lubrification permanente et ne nécessite aucun entretien. Voir tableau 1 concernant les huiles et les quantités conseillées. Les charges radiales et axiales applicables au réducteur sont précisées dans le tableau 2.

**E** El reductor tamaño **114C** se suministra, lubricado de por vida con aceite sintético y no requieren mantenimiento alguna. Ver tabla 1, para cantidades y aceites recomendados. En la tabla 2, se encuentran las cargas radiales y axiales admitidas por el reductor.

Standard supplied	For these mounting position specify in the order or add oil Per queste posizioni specificare in fase d'ordine o aggiungere olio					
B3	B6	B7	B8	V5	V6	V8
4.10 LT	2.70 LT	2.70 LT	2.70 LT	5.30 LT	2.35 LT	Ask
SHELL Omala S4 WE 320				ENI Telium VSF 320		

For all details on lubrication and plugs check our website **tab. 1**  
Per maggiori dettagli su lubrificazione e tappi olio vedi il nostro sito web

### RADIAL AND AXIAL LOADS

Output shaft Albero di uscita			Feq = FR $\frac{171}{X+131}$		
n <sub>2</sub>	FA	FR	n <sub>2</sub>	FA	FR
300	640	3200	140	860	4300
250	700	3500	120	900	4500
200	740	3700	85	1000	5000
n <sub>2</sub>	FA	FR	n <sub>2</sub>	FA	FR
70	1080	5400	40	1300	6500
15	1840	9200			

**On request reinforced bearings to increase loads.**  
A richiesta cuscinetti rinforzati per aumentare i carichi.

**Input shaft**  
Albero in entrata

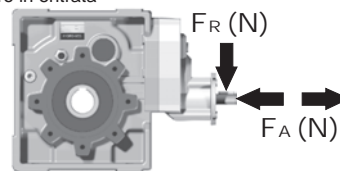

n <sub>1</sub>	FA	FR
1400	240	1200
900	280	1400
500	310	1700

**tab. 2**

3D dimensions on the Web

**P114CC...** Basic Gearbox  
Riduttore base

Gearbox weight **38.0 kg**  
peso riduttore

M. flanges	Kit code	øF	A
63B5	K063.4.041	140	252.5
71B5	K063.4.042	160	250.5
80/90B5	K063.4.043	200	252.5
71B14	K063.4.047	105	250.5
80B14	K063.4.046	120	252.5
90B14	K063.4.041	140	252.5

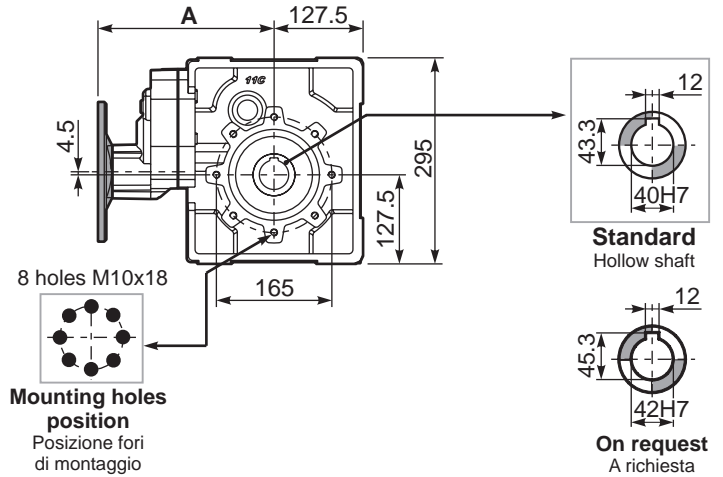
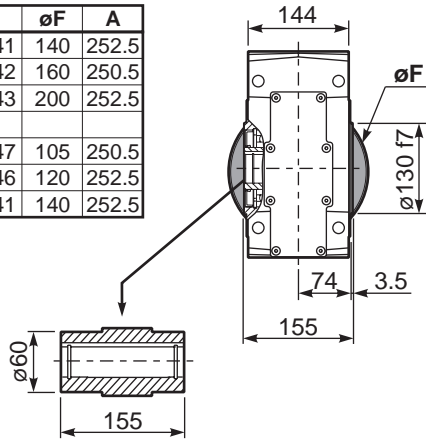

**P114C...FB..** Feet  
Piedini

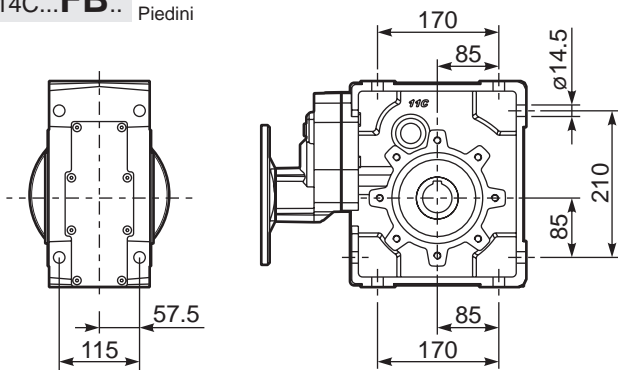

**P114C...-FC..** Output flange  
Flangia uscita

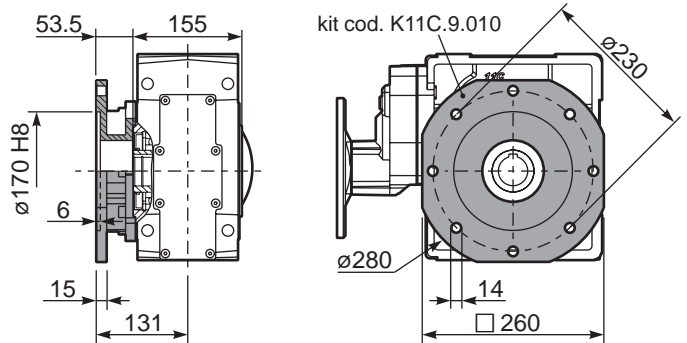

**P114C...-FL..** Output flange  
Flangia uscita

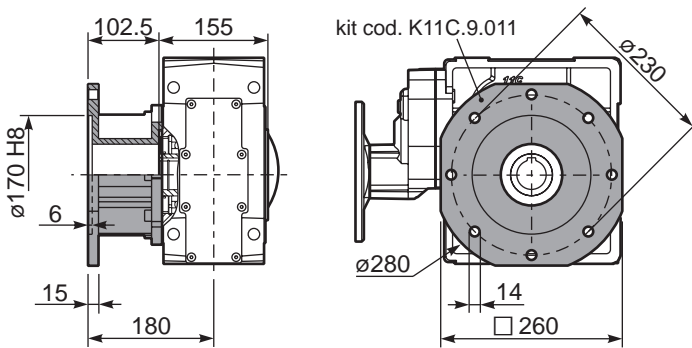

**P114C...BR..** Reaction Arm  
Braccio di reazione

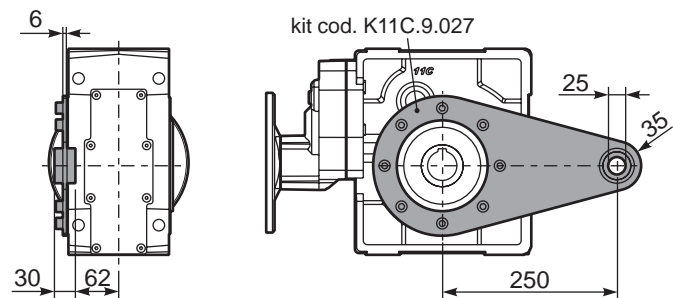

**R114C...** Input shaft  
Albero in entrata

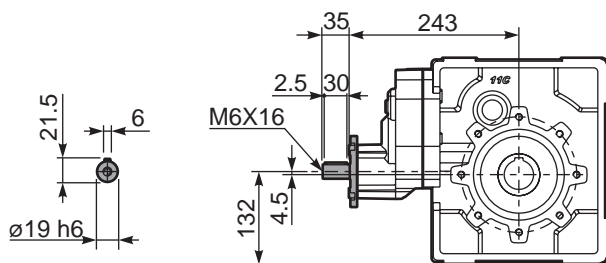

**P114CA...** Single shaft  
Albero lento semplice

**P114CB...** Double shaft  
Albero lento bisp.

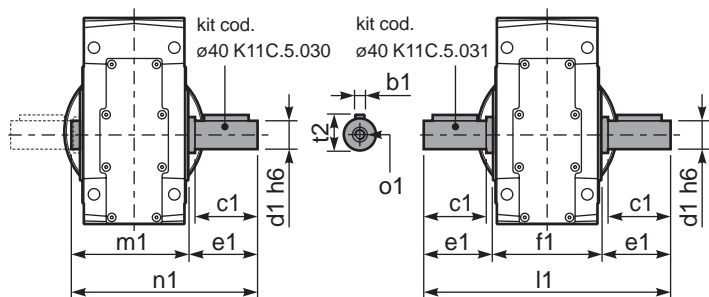

	b1	c1	d1	e1	f1	l1	m1	n1	t2	o1
ø40 Standard	12	80	40	84.5	155	324	164.5	249	43	M12
On request	-	-	-	-	-	-	-	-	-	-