



## QUICK SELECTION / Selezione veloce

input speed ( $n_1$ ) = 1400 min<sup>-1</sup>

Output Speed $n_2$ [min <sup>-1</sup> ]	Ratio $i$	Motor power $P_{1M}$ [kW]	Output torque $M_{2M}$ [Nm]	Service factor f.s.	Nominal power $P_{1R}$ [kW]	Nominal torque $M_{2R}$ [Nm]	Available B5 motor flanges					Available B14 motor flanges				Output Shaft 	Ratios code 
							-C	-D	-E	-F	-G	-R	-T	-U	-V		
							71	80	90	100 112	132	80	90	100 112	132		
175	<b>8.02</b>	9	473	1.1	<b>9.9</b>	<b>520</b>	B									3018	01
152	<b>9.18</b>	9	541	1.1	<b>9.8</b>	<b>590</b>	B									3016	02
131	<b>10.68</b>	9	630	1.1	<b>9.7</b>	<b>680</b>	B									3014	03
93	<b>15.11</b>	7.5	717	1.1	<b>7.8</b>	<b>775</b>	B									2018	04
81	<b>17.30</b>	7.5	821	1.1	<b>7.8</b>	<b>885</b>	B									2016	05
70	<b>20.13</b>	7.5	955	0.9	<b>6.8</b>	<b>900</b>	B									2014	06
60	<b>23.39</b>	5.5	820	1.1	<b>5.9</b>	<b>900</b>	B									1616	07
51	<b>27.21</b>	5.5	954	0.9	<b>5.1</b>	<b>900</b>	B									1614	08
46.0	<b>30.42</b>	4	780	1.2	<b>4.5</b>	<b>900</b>	B									1316	09
39.6	<b>35.38</b>	4	907	1.0	<b>3.9</b>	<b>900</b>	B									1314	10
37.6	<b>37.24</b>	3	719	1.2	<b>3.7</b>	<b>895</b>	B									1116	11
32.3	<b>43.31</b>	3	836	1.1	<b>3.2</b>	<b>900</b>	B									1114	12
29.8	<b>47.02</b>	2.2	668	1.1	<b>2.3</b>	<b>705</b>	B									818	13
26.0	<b>53.85</b>	2.2	765	1.1	<b>2.3</b>	<b>810</b>	B									816	14
22.4	<b>62.63</b>	2.2	890	1.0	<b>2.2</b>	<b>900</b>	B									814	15
18.9	<b>74.16</b>	1.1	531	1.1	<b>1.2</b>	<b>585</b>	B									616	16
16.2	<b>86.25</b>	1.1	617	1.1	<b>1.2</b>	<b>680</b>	B									614	17

The dynamic efficiency is **0.96** for all ratios

**Motor Flanges Available**  
Flange Motore Disponibili

**B) Supplied with Reduction Bushing**  
Fornito con Bussola di Riduzione

**B) Available on Request without reduction bushing**  
Disponibile a Richiesta senza Bussola di Riduzione

**C) Motor Flange Holes Position**  
Posizione Fori Flangia Motore

**EN** Unit **H72C** is supplied without lubricant and equipped with a breather, level and drain plugs. User can add mineral oil keeping existing plugs. Should the user wish to fill it with synthetic oil, it is recommended to replace the existing plugs with a closed plug. See table 1 for lubrication and recommended quantity. In table 2 please see possible radial loads and axial loads on the gearbox.

**I** Il riduttore tipo **H72C** è fornito privo di lubrificazione con tappi di sfiato, livello e scarico olio. L'utente può immettere olio minerale mantenendo i tappi esistenti. Se immetterà olio sintetico, dovrà sostituire i tappi esistenti con altri tipo chiuso. Tab.1 per oli e quantità consigliati. Tab.2 carichi radiali e assiali applicabili al riduttore.

**D** Das Getriebe der Baugröße **H72C** wird ohne Schmiermittel geliefert. Es ist jedoch mit Einfüllschraube, Überdruckventil und Ablassschraube ausgerüstet. Das benötigte mineralische Öl kann über die Einfüllschraube eingefüllt werden. Sollte synthetisches Öl bevorzugt werden, so ist sind das eingebaute Überdruckventil durch eine geschlossenen Schraube zu ersetzen. In Tabelle 1 ist die Schmiermenge und das empfohlene Schmiermittel angegeben. In Tabelle 2 sind die zulässigen Radial - und Axialbelastungen des Getriebes aufgeführt.

**F** Le réducteur de type **H72C** est fourni sans lubrification et avec un bouchon de remplissage, de niveau et d'évacuation de l'huile. L'utilisateur peut y verser de l'huile minérale en conservant les bouchons existants. S'il y versera de l'huile synthétique, il devra substituer les bouchons existants avec d'autres bouchons de type fermé. Voir tableau 1 concernant les huiles et les quantités conseillées. Voir tableau 2 concernant les charges radiales et axiales applicables au réducteur.

**E** El reductor tamaño **H72C** se suministra sin lubricante, provisto de tapones de respiración, nivel y descarga de aceite. El usuario puede utilizar aceite mineral, manteniendo los tapones existentes. Si prefiere utilizar aceite sintético deberá sustituir los tapones existentes por tapones ciegos. La prerreducción se suministra con tapones ciegos, lubricado de por vida con aceite sintético. Ver tabla 1, para cantidades y aceites recomendados. En la tabla 2, se encuentran las cargas radiales y axiales admitidas por el reductor.

B3	B6	B7	B8	V5	V6	V8
3.20 LT	4.65 LT	4.00 LT	3.20 LT	6.20 LT	3.10 LT	Ask
SHELL Omala S2 GX 460				ENI Blasias 460		

For all details on lubrication and plugs check our website **tab. 1**  
Per maggiori dettagli su lubrificazione e tappi olio vedi il nostro sito web

### RADIAL AND AXIAL LOADS

**Output shaft**  
Albero di uscita

$F_{eq} = F_R \cdot \frac{174.5}{X+134.5}$

$n_2$	FA	FR	$n_2$	FA	FR	$n_2$	FA	FR
300	740	3700	140	860	4300	70	1020	5100
250	800	4000	120	900	4500	40	1300	6500
200	830	4150	85	970	4850	15	1700	8500

**On request reinforced bearings to increase loads.**  
A richiesta cuscinetti rinforzati per aumentare i carichi.

**Input shaft**  
Albero in entrata

$n_1$	FA	FR
1400	450	2250
900	500	2500
500	600	3000

tab. 2

**PH72C...** Basic gearbox  
Riduttore base

M. flanges	Kit code	øF	A
71B5	K023.4.041	160	238.5
80/90B5	K023.4.042	200	240.5
100/112B5	K023.4.043	250	249.5
132B5	KC51.4.043	300	270.5
<hr/>			
80B14	K085.4.046	120	240.5
90B14	K085.4.045	140	240.5
100/112B14	K085.4.047	160	249.5
132B14	KC51.4.041	200	270.5

Gearbox weight  
peso riduttore **46.0 kg**

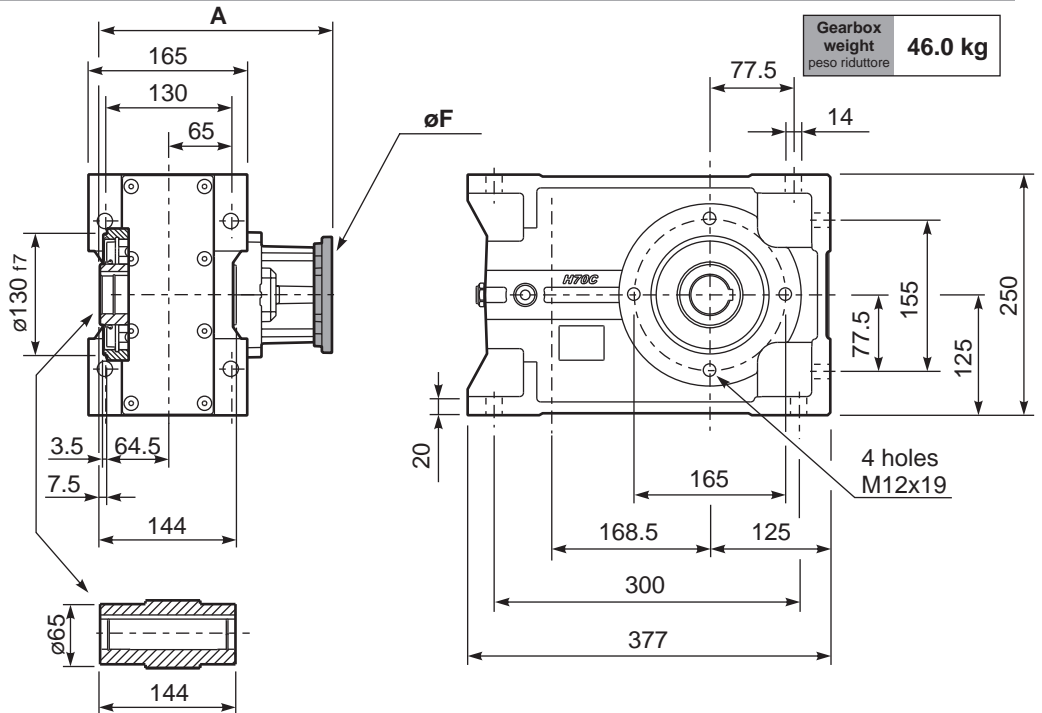

**Standard**  
Hollow shaft

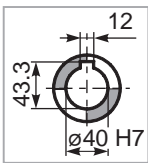

**On request**  
A richiesta

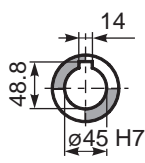

**PH72C...-F** Output flange  
Flangia uscita

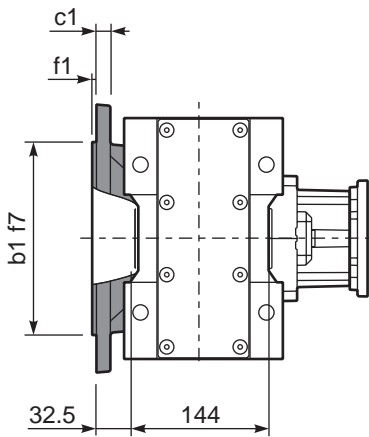

**PH72C D...** Shrink disk  
Calettatore

Kit. Cod KF70.0.210LM

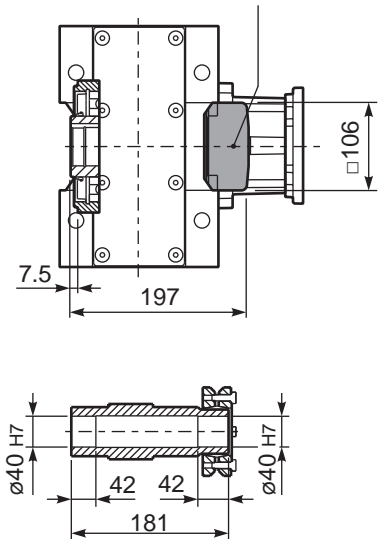

**Available output flanges**

Flange di uscita

a1 ø	b1	c1	e1	f1	s1	Kit code
250	180	13	215	3	14	KF70.9.011
300	230	16	265	4	14	KF70.9.012

**RH72C...** Input Shaft  
Albero in entrata

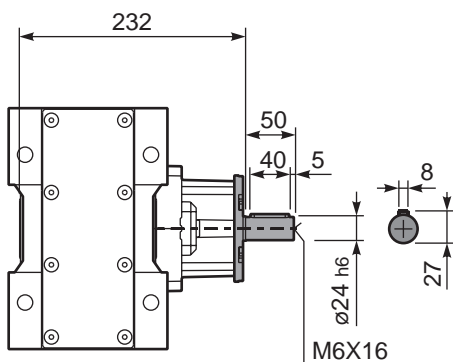

**PH72C A...** Single output shaft  
Albero uscita semplice

Kit. Cod KF70.5.028

