



QUICK SELECTION / Selezione veloce

input speed (n_1) = 1400 min⁻¹

Output Speed n_2 [min ⁻¹]	Ratio i	Motor power P_{1M} [kW]	Output torque M_{2M} [Nm]	Service factor f.s.	Nominal power P_{1R} [kW]	Nominal torque M_{2R} [Nm]	Available B5 motor flanges				Available B14 motor flanges			Output Shaft 	Ratios code
							-B	-C	-D	-E	-Q	-R	-T		
							63	71	80	90	71	80	90		
22.6	61.89	1.5	594	1.1	1.7	675	B				C	C		191318	01
19.7	71.16	1.5	683	1.0	1.5	675	B				C	C		191316	02
17.0	82.48	1.5	792	0.9	1.3	675	B				C	C		171316	03
14.5	96.29	1.1	675	1.0	1.1	675	B				C	C		171314	04
13.9	100.51	1.1	705	1.0	1.0	675	B				C	C		131318	05
12.1	115.56	0.75	556	1.2	0.91	675	B				C	C		131316	06
11.1	125.96	0.75	606	1.1	0.82	665	B				C	C		190816	07
10.4	134.91	0.75	649	1.0	0.78	675	B				C	C		131314	08
9.5	147.05	0.75	707	1.0	0.72	675	B				C	C		190814	09
8.2	170.44	0.55	605	1.1	0.62	675	B				C	C		170814	10
7.6	184.15	0.55	653	1.0	0.57	675	B				C	C		101314	11
6.8	205.87	0.55	730	0.9	0.51	675	B				C	C		91316	12
5.8	240.34	0.37	570	1.2	0.44	675	B				C	C		91314	13
5.0	279.22	0.37	662	1.0	0.37	665	B				C	C		100816	14
4.3	325.97	0.37	773	0.9	0.32	675	B				C	C		100814	15
3.8	364.41	0.25	583	1.1	0.28	665	B				C	C		90816	16
3.3	425.43	0.25	681	1.0	0.25	675	B				C	C		90814	17
2.9	481.19	0.18	589	1.1	0.22	665	B				C	C		70816	18
2.5	561.76	0.18	687	1.0	0.19	675	B				C	C		70814	19

The dynamic efficiency is **0.94** for all ratios

Motor Flanges Available
Flange Motore Disponibili

B) Supplied with Reduction Bushing
Fornito con Bussola di Riduzione

B) Available on Request without reduction bushing
Disponibile a Richiesta senza Bussola di Riduzione

C) Motor Flange Holes Position
Posizione Fori Flangia Motore

EN Unit **H63C** is supplied with synthetic oil for lifetime lubrication, no maintenance is necessary. See table 1 for lubrication and recommended quantity. In table 2 please see possible radial loads and axial loads on the gearbox.

I Il riduttore **H63C** viene fornito completo di olio sintetico per la lubrificazione permanente e non necessita di alcuna manutenzione. Vedi tab.1 per oli e quantità consigliati. In tab.2 sono presenti i carichi radiali e assiali applicabili al riduttore.

D Das Getriebe **H63C** ist mit synthetischem Öl gefüllt und ist lebensdauergeschmiert. In Tabelle 1 ist die Schmiermenge und das empfohlene Schmiermittel angegeben. In Tabelle 2 sind die zulässigen Radial - und Axialbelastungen des Getriebes aufgeführt.

F Le réducteur **H63C** est fourni complet avec de l'huile synthétique pour la lubrification permanente et ne nécessite aucun entretien. Voir tableau 1 concernant les huiles et les quantités conseillées. Les charges radiales et axiales applicables au réducteur sont précisées dans le tableau 2.

E El reductor tamaño **H63C** se suministra, lubricado de por vida con aceite sintético y no requieren mantenimiento alguna. Ver tabla 1, para cantidades y aceites recomendados. En la tabla 2, se encuentran las cargas radiales y axiales admitidas por el reductor.

Standard supplied	For these mounting position specify in the order or add oil Per queste posizioni specificare in fase d'ordine o aggiungere olio						
B3	B6	B7	B8	V5	V6	V8	
2.35 LT	3.85 LT	3.15 LT	2.35 LT	4.55 LT	2.50 LT	Ask	
SHELL Omala S4 WE 320				ENI Telium VSF 320			

For all details on lubrication and plugs check our website **tab. 1**
Per maggiori dettagli su lubrificazione e tappi olio vedi il nostro sito web

RADIAL AND AXIAL LOADS

Output shaft
Albero di uscita

$F_{eq} = F_R \cdot \frac{149.5}{X+119.5}$

n_2	FA	FR	n_2	FA	FR	n_2	FA	FR
300	600	3000	140	720	3600	70	940	4700
250	640	3200	120	740	3700	40	1220	6100
200	690	3460	85	860	4300	15	1300	6500

On request reinforced bearings to increase loads.

A richiesta cuscinetti rinforzati per aumentare i carichi.

Input shaft
Albero in entrata

n_1	FA	FR
1400	240	1200
900	280	1400
500	340	1700

tab. 2

PH63C... Basic gearbox
Riduttore base

M. flanges	Kit code	øF	A
63B5	K063.4.041	140	239
71B5	K063.4.042	160	237
80/90B5	K063.4.043	200	239
71B14	K063.4.047	105	237
80B14	K063.4.046	120	239
90B14	K063.4.041	140	239

Standard
Hollow shaft

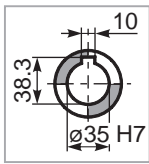

On request
A richiesta

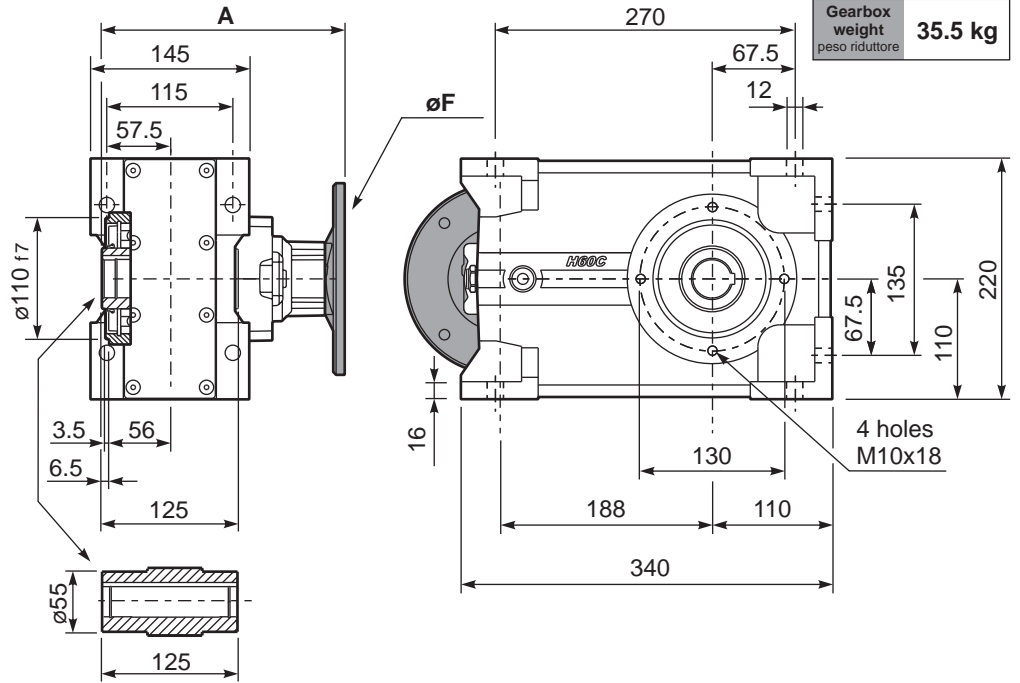
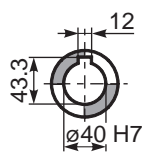

Gearbox weight
peso riduttore **35.5 kg**

PH63C...-F Output flange
Flangia uscita

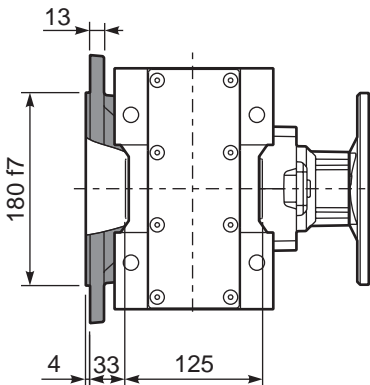

Kit. Cod KF60.9.011

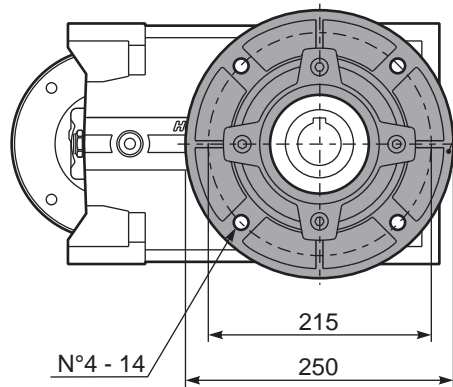

PH63C D... Shrink disk
Calettatore

Kit. Cod KF60.0.210LM

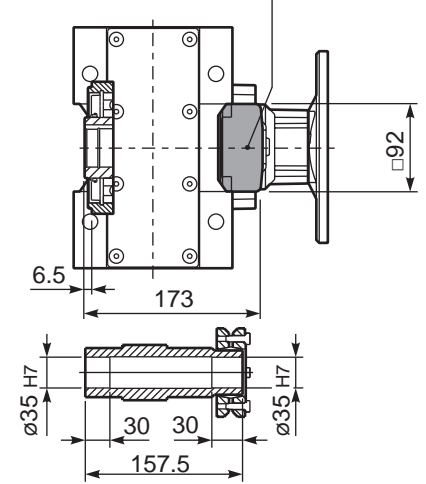

RH63C... Input Shaft
Albero in entrata

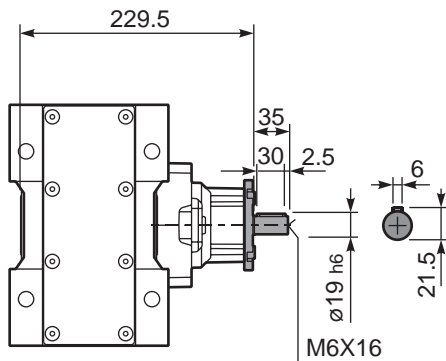

PH63C A... Single output shaft
Albero uscita semplice

