



### QUICK SELECTION / Selezione veloce

input speed ( $n_1$ ) = 1400 min<sup>-1</sup>

Output Speed $n_2$ [min <sup>-1</sup> ]	Ratio $i$	Motor power $P_{1M}$ [kW]	Output torque $M_{2M}$ [Nm]	Service factor f.s.	Nominal power $P_{1R}$ [kW]	Nominal torque $M_{2R}$ [Nm]	Available B5 motor flanges		Available B14 motor flanges			Hollow Shaft  standard ø17	Ratios code 
							-B	-C	-O	-P	-Q		
							63	71	56	63	71		
72	<b>19.42</b>	0.37	46	1.3	<b>0.48</b>	<b>60</b>			C	C		281713	01
51	<b>27.21</b>	0.37	65	0.9	<b>0.34</b>	<b>60</b>			C	C		281313	02
36.4	<b>38.49</b>	0.25	62	1.0	<b>0.24</b>	<b>60</b>			C	C		191713	03
31.7	<b>44.12</b>	0.18	54	1.1	<b>0.21</b>	<b>60</b>			C	C		171713	04
26.7	<b>52.50</b>	0.18	64	0.9	<b>0.18</b>	<b>60</b>			C	C		151713	05
22.6	<b>61.82</b>	0.12	49	1.2	<b>0.15</b>	<b>60</b>			C	C		171313	06
19.0	<b>73.56</b>	0.12	58	1.0	<b>0.13</b>	<b>60</b>			C	C		151313	07
15.9	<b>88.13</b>	0.09	56	1.1	<b>0.11</b>	<b>60</b>			C	C		101713	08
12.0	<b>116.67</b>	0.06	48	1.2	<b>0.08</b>	<b>60</b>			C	C		91713	09
11.3	<b>123.48</b>	0.06	51	1.2	<b>0.08</b>	<b>60</b>			C	C		101313	10
9.0	<b>155.37</b>	0.06	64	0.9	<b>0.06</b>	<b>60</b>			C	C		71713	11
8.6	<b>163.47</b>	0.06	68	0.9	<b>0.06</b>	<b>60</b>			C	C		91313	12
7.6	<b>184.39</b>	0.06	76	0.8	<b>0.05</b>	<b>60</b>			C	C		61713	13
6.4	<b>217.68</b>	0.06*	90	0.7	<b>0.04</b>	<b>60</b>			C	C		71313	14
5.4	<b>258.34</b>	0.06*	107	0.6	<b>0.04</b>	<b>60</b>			C	C		61313	15

The dynamic efficiency is **0.94** for all ratios \* Power higher than the maximum one which can be supported by the gearbox. Select according to the torque  $M_{2R}$   
Potenza superiore a quella massima sopportabile dal riduttore. Selezionare in base al momento torcente  $M_{2R}$

- Motor Flanges Available** Flange Motore Disponibili
- B) Supplied with Reduction Bushing** Fornito con Bussola di Riduzione
- B) Available on Request without reduction bushing** Disponibile a Richiesta senza Bussola di Riduzione
- C) Motor Flange Holes Position** Posizione Fori Flangia Motore

**EN** Unit **FS10** is supplied with synthetic oil for lifetime lubrication, no maintenance is necessary. See table 1 for lubrication and recommended quantity. In table 2 please see possible radial loads and axial loads on the gearbox.

**I** Il riduttore **FS10** viene fornito completo di olio sintetico per la lubrificazione permanente e non necessita di alcuna manutenzione. Vedi tab.1 per oli e quantità consigliati. In tab.2 sono presenti i carichi radiali e assiali applicabili al riduttore.

**D** Das Getriebe **FS10** ist mit synthetischem Öl gefüllt und ist lebensdauergeschmiert. In Tabelle 1 ist die Schmiermenge und das empfohlene Schmiermittel angegeben. In Tabelle 2 sind die zulässigen Radial - und Axialbelastungen des Getriebes aufgeführt.

**F** Le réducteur **FS10** est fourni complet avec de l'huile synthétique pour la lubrification permanente et ne nécessite aucun entretien. Voir tableau 1 concernant les huiles et les quantités conseillées. Les charges radiales et axiales applicables au réducteur sont précisées dans le tableau 2.

**E** El reductor tamaño **FS10** se suministra, lubricado de por vida con aceite sintético y no requieren mantenimiento alguna. Ver tabla 1, para cantidades y aceites recomendados. En la tabla 2, se encuentran las cargas radiales y axiales admitidas por el reductor.

### LUBRICATION FS10 Oil Quantity 0.35 Lt.

**SHELL** Omala S4 WE 320      **ENI** Telium VSF 320

For all details on lubrication and plugs check our website **tab. 1**  
Per maggiori dettagli su lubrificazione e tappi olio vedi il nostro sito web

### RADIAL LOADS

Input shaft  
Albero in entrata

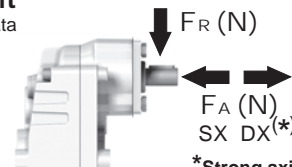

$n_1$	FA	FR
1400	140	700
900	160	800

\*Strong axial loads in the DX direction are not allowed.  
Non sono consentiti forti carichi assiali con direzione DX

**tab. 2**

**P**FS10... Basic gearbox  
Riduttore base

Gearbox weight **3.1 kg**  
peso riduttore

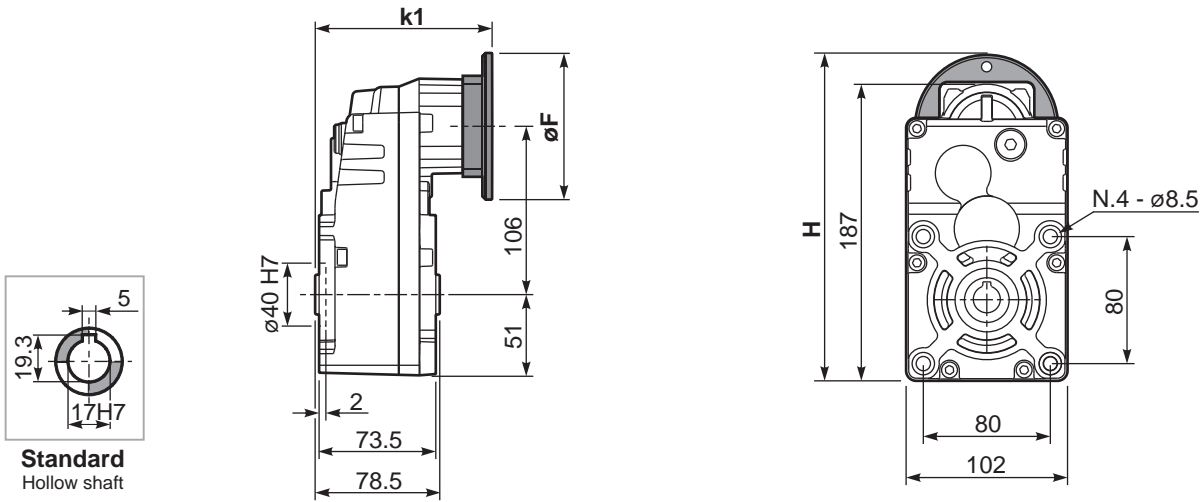

B14 Motor Flanges	H	øF	k1	kit code
56 B14	197	80	109.3	KC40.4.049
63 B14	202	90	111.8	K050.4.047
71 B14	209.5	105	109.3	K050.4.045

B5 Motor Flanges	H	øF	k1	kit code
63 B5	226	138	111.8	K050.4.041
71 B5	237	160	109.3	K050.4.042

**R**FS10... Input Shaft  
Albero in entrata

