



QUICK SELECTION / Selezione veloce

input speed (n_1) = 1400 min⁻¹

Output Speed n_2 [min ⁻¹]	Ratio i	Motor power P_{1M} [kW]	Output torque M_{2M} [Nm]	Service factor f.s.	Nominal power P_{1R} [kW]	Nominal torque M_{2R} [Nm]	Available B5 motor flanges					Available B14 motor flanges				Output Shaft 	Ratios code
							-C	-D	-E	-F	-G	-R	-T	-U	-V		
							71	80	90	100 112	132	80	90	100 112	132		
213	6.57	7.5	312	1.2	8.8	380	B									3018	01
185	7.56	7.5	358	1.1	7.9	390	B									3016	02
159	8.82	7.5	419	1.0	7.1	410	B									3014	03
113	12.39	7.5	588	1.0	7.2	580	B									2018	04
98	14.24	5.5	499	1.2	6.4	600	B									2016	05
84	16.75	5.5	587	1.1	6.1	665	B									1618	06
73	19.25	5.5	675	1.0	5.4	675	B									1616	07
64	21.78	4	558	1.2	4.7	675	B									1318	08
56	25.04	4	642	1.1	4.1	675	B									1316	09
47.9	29.23	4	750	0.9	3.5	675	B									1314	10
45.7	30.65	3	592	1.1	3.4	675	B									1116	11
39.1	35.78	3	691	1.0	2.9	675	B									1114	12
36.3	38.55	2.2	548	1.1	2.3	580	B									818	13
31.6	44.32	2.2	630	1.1	2.3	665	B									816	14
27.1	51.74	2.2	735	0.9	2.0	675	B									814	15
22.9	61.03	1.1	437	1.1	1.2	480	B									616	16
19.6	71.25	1.1	510	1.1	1.2	560	B									614	17

The dynamic efficiency is **0.96** for all ratios

- Motor Flanges Available
Flange Motore Disponibili
- Supplied with Reduction Bushing
Fornito con Bussola di Riduzione
- Available on Request without reduction bushing
Disponibile a Richiesta senza Bussola di Riduzione
- Motor Flange Holes Position
Posizione Fori Flangia Motore

EN Unit **FC62** is supplied with synthetic oil for lifetime lubrication, no maintenance is necessary. See table 1 for lubrication and recommended quantity. In table 2 please see possible radial loads and axial loads on the gearbox.

I Il riduttore **FC62** viene fornito completo di olio sintetico per la lubrificazione permanente e non necessita di alcuna manutenzione. Vedi tab.1 per oli e quantità consigliati. In tab.2 sono presenti i carichi radiali e assiali applicabili al riduttore.

D Das Getriebe **FC62** ist mit synthetischem Öl gefüllt und ist lebensdauergeschmiert. In Tabelle 1 ist die Schmiermenge und das empfohlene Schmiermittel angegeben. In Tabelle 2 sind die zulässigen Radial - und Axialbelastungen des Getriebes aufgeführt.

F Le réducteur **FC62** est fourni complet avec de l'huile synthétique pour la lubrification permanente et ne nécessite aucun entretien. Voir tableau 1 concernant les huiles et les quantités conseillées. Les charges radiales et axiales applicables au réducteur sont précisées dans le tableau 2.

E El reductor tamaño **FC62** se suministra, lubricado de por vida con aceite sintético y no requieren mantenimiento alguna. Ver tabla 1, para cantidades y aceites recomendados. En la tabla 2, se encuentran las cargas radiales y axiales admitidas por el reductor.

Standard supplied	For these mounting position specify in the order or add oil Per queste posizioni specificare in fase d'ordine o aggiungere olio				
H1	H4	H3	H2	H5	H6
2.05 LT	1.25 LT	1.25 LT	1.40 LT	2.20 LT	1.40 LT
SHELL Omala S4 WE 320			ENI Telium VSF 320		

For all details on lubrication and plugs check our website **tab. 1**
Per maggiori dettagli su lubrificazione e tappi olio vedi il nostro sito web

RADIAL AND AXIAL LOADS

Output shaft
Albero di uscita

$F_{eq} = FR \cdot \frac{149.5}{X+119.5}$

n_2	FA	FR	n_2	FA	FR	n_2	FA	FR
300	600	3000	140	720	3600	70	940	4700
250	640	3200	120	740	3700	40	1220	6100
200	690	3460	85	860	4300	15	1300	6500

On request reinforced bearings to increase loads.
A richiesta cuscinetti rinforzati per aumentare i carichi.

Input shaft
Albero in entrata

n_1	FA	FR
1400	450	2250
900	500	2500
500	600	3000

tab. 2

PFC62C... Basic gearbox
Riduttore base

Gearbox weight
peso riduttore **20.8 kg**

M. flanges	Kit code	øF	A
71B5	K023.4.041	160	227
80/90B5	K023.4.042	200	229
100/112B5	K023.4.043	250	238
132B5	KC51.4.043	300	259
80B14	K085.4.046	120	229
90B14	K085.4.045	140	229
100/112B14	K085.4.047	160	238
132B14	KC51.4.041	200	259

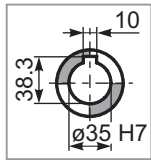
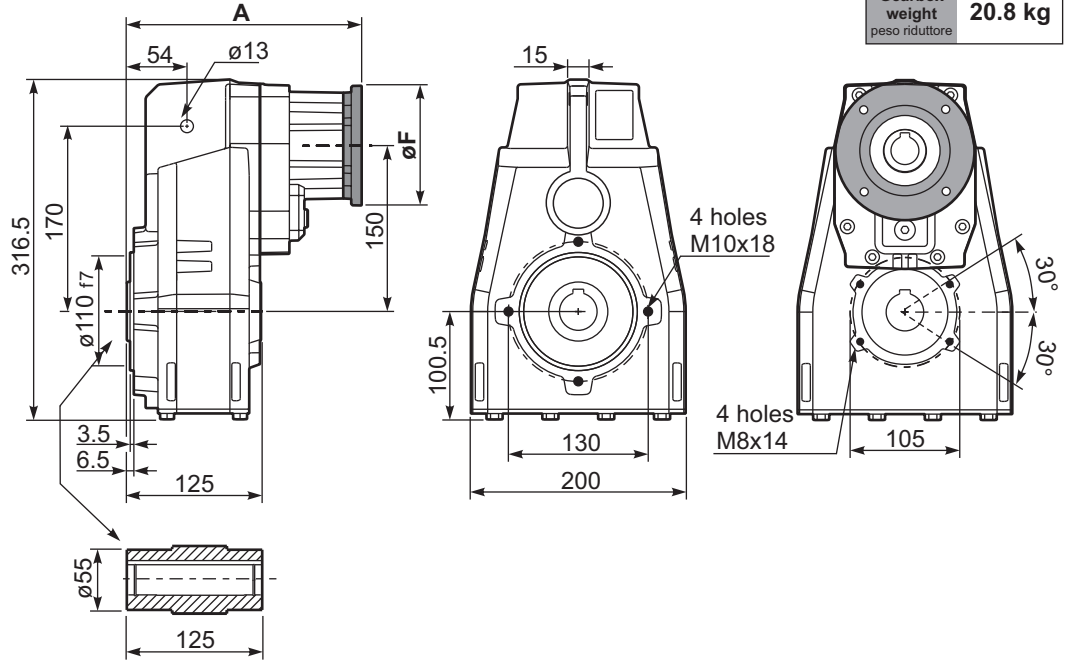

Standard
Hollow shaft

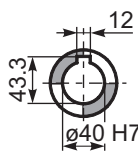

On request
A richiesta

PFC62...-F... Output flange
Flangia uscita

M. flanges	k1
71B5	260
80/90B5	262
100/112B5	271
132B5	289
80B14	262
90B14	262
100/112B14	271
132B14	289

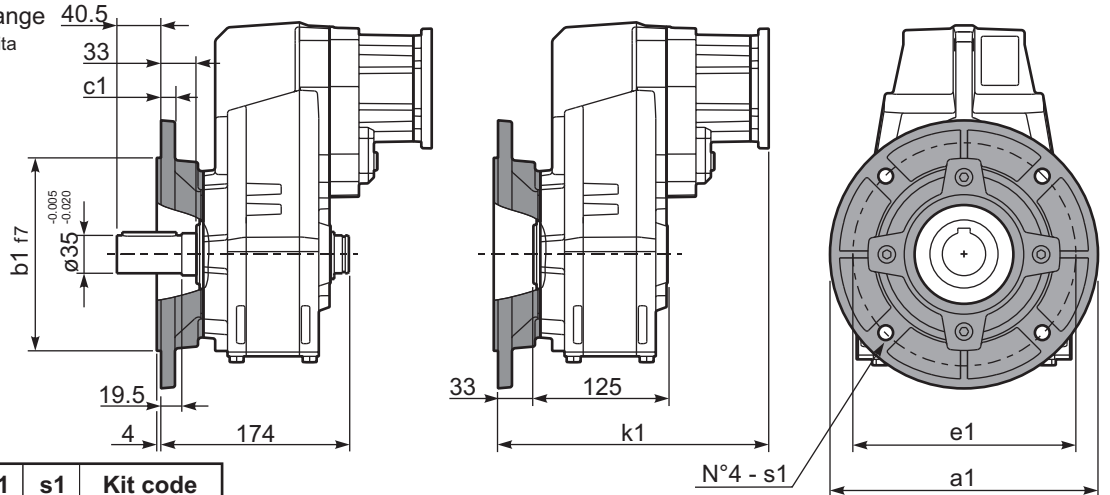

Available output flanges
Flange di uscita

a1 ø	b1	c1	e1	s1	Kit code
250	180	13	215	14	KF60.9.011
-	-	-	-	-	-

RFC62C... Input Shaft
Albero in entrata

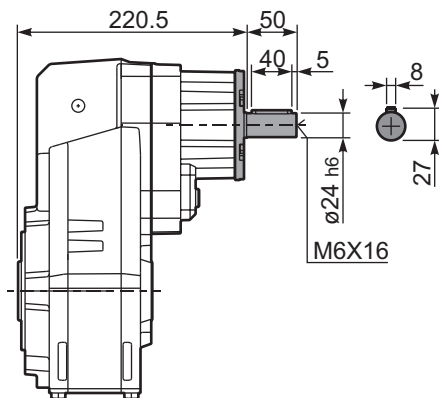

PFC62 A... Single output shaft
Albero uscita semplice

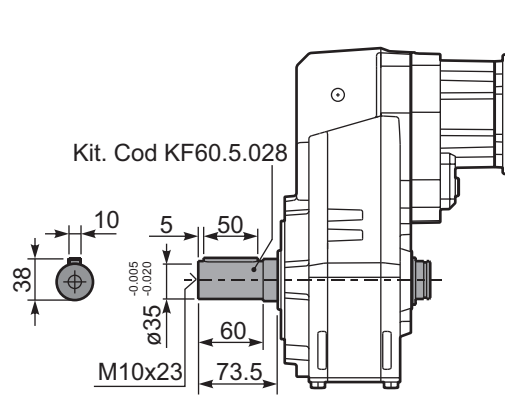

PFC62D... Shrink disk
Calettatore

