

# PRZEKŁADNIE WALCOWE ERC



**pro-MOTOR**

## Spis treści

1. Informacje ogólne	<b>s. 3</b>	▶ SUMMARIZE
2. Typy przekładni	<b>s. 4</b>	▶ PRODUCT STRUCTURE PICTURE
3. Opis modelu	<b>s. 5</b>	▶ MODEL ILLUMINATE
4 - 7. Najważniejsze parametry	<b>s. 6-22</b>	▶ RELEVANT PARAMETER
8. Karta wymiarów gabarytowych	<b>s. 23-30</b>	▶ SELECTION EXAMPLE
9. Położenia montażowe	<b>s. 31</b>	▶ RATIO AND IEC MOTOR ADAPTERS
10. Smarowanie	<b>s. 31-32</b>	▶ SELECTION TABLES
11. Sposoby montażu	<b>s. 32-33</b>	▶ OUTLINE DIMENSION SHEET
12. Naprawa usterek	<b>s. 34</b>	▶ INSTALLATION POSITIONS
13. Karta charakterystyki	<b>s. 35-36</b>	▶ LUBRICATION
14. Notatki	<b>s. 37</b>	▶ INSTALLATION METHODS
15. Prezentacja produktów firmy PROMOTOR	<b>s. 38-39</b>	▶ CORRECT THE MALFUNCTIONS ▶ ADDENDUM ▶ SHOW THE SERIES PRODUCTS

## 1. INFORMACJE OGÓLNE

Przekładnie z kołem zębatym walcowym o zębach skośnych ERC to nowa generacja mechaniczno-elektrycznych produktów, które zaprojektowane zostały jako system modułowy. Współpracują ze zwykłymi silnikami, silnikami z hamulcem, silnikami w wykonaniu przeciwwybuchowym, silnikami zasilanymi z falowników, serwowmotorami, silnikami IEC, itp. Istnieje możliwość dowolnego montażu w sześciu płaszczyznach na stabilnym podłożu. Produkty tego typu znajdują zastosowanie w różnych sektorach przemysłu takich jak przemysł tekstylny, spożywczy, napojów, chemiczny, wysięgników, automatycznego sprzętu do magazynowania, metalurgicznym, tytoniowym, ochrony środowiska, logistyki, itp.

### 1.1 Charakterystyka produktu

- Modułowość,
- Wysoka sprawność,
- Niski poziom hałasu,
- Niewielkie gabaryty, kompaktowa budowa,
- Uniwersalne mocowanie,
- Aluminiowa obudowa, niewielka waga,
- Koła nawęglane, wytrzymałe,
- Uniwersalna konstrukcja, umożliwiająca montaż w dowolny sposób, odpowiedni do wymogów danego rozwiązania technologicznego.

Przekładnie z kołem zębatym walcowym o zębach skośnych ERC produkowane są w ponad 4 rodzajach. Moc 0,12-5,5kW; Przełożenie 3,66-54; Moment maks. 120 – 500 Nm. Dowolny montaż (łapy, kołnierz) w wybranej pozycji, zgodnie z wymogami klienta.

## 1. SUMMARIZE

ERC Series helical gear units is a new generation mechanic-electrical integrated product, which designed basing on the modular system. It can be connected respectively with motors such as normal motor, brake motor, explosion-proof motor, frequency conversion motor, servo motor, IEC motor and so on. It can be mounted discretionary six orientation in solid space. This kind of product is widely used in drive fields such as textile, foodstuff, beverage, chemical industry, automatic arm ladder, automatic storage equipment, metallurgy, tobacco, environment-protection, logistics and so on.

### 1.1 Products characteristics

- Modularity;
- High efficiency;
- Low noise;
- Space effective, refined design;
- Universal mounting;
- Aluminium housing, light in weight;
- Gears in carbonize hard, durable;
- Multistructure, can be combined in many forms to meet needs of all kinds of transmission conditions.

ERC Series helical gear units has more than 4 types. Power 0.12-5.5KW; Ratio 3.66-54; Torque max 120-500Nm. It can be connected (foot, flange) discretionary and use multi-mounting positions according to customers' requirements.

## 1.2 Budowa / Structure feature

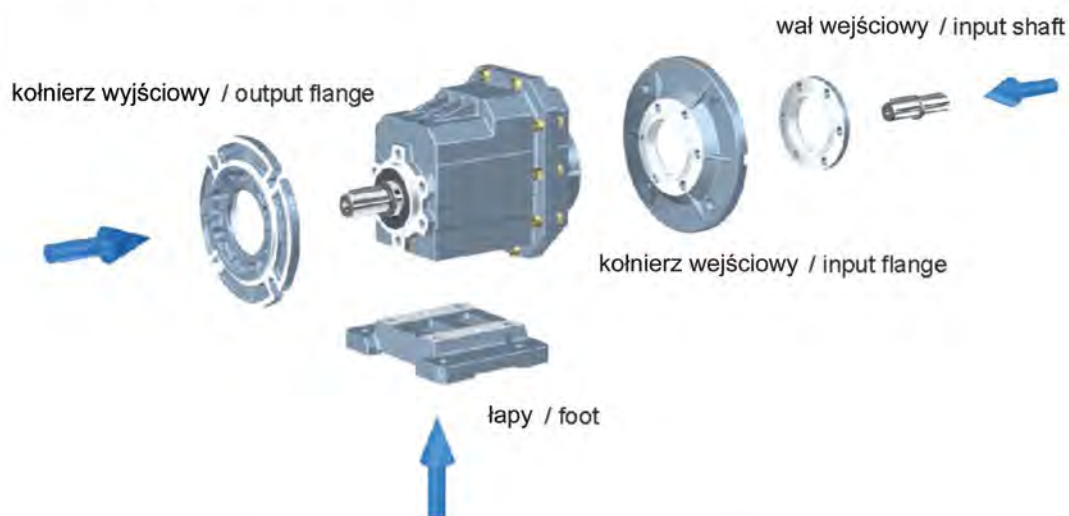

## 2. TYPY PRZEKŁADNI / PRODUCT STRUCTURE PICTURE



### **ERC..P(IEC)**

Przekładnia z kołem zębatym walcowym o zębach skośnych montowana na łapach  
Foot-mounted helical gear unit



### **ERC..HS**

Przekładnia z kołem zębatym walcowym o zębach skośnych montowana na łapach z wałem wejściowym  
Shaft input foot-mounted helical gear unit



### **ERCF..P(IEC)**

Przekładnia z kołem zębatym walcowym o zębach skośnych montowana na kołnierzu  
Flange-mounted helical gear unit



### **ERCF..HS**

Przekładnia z kołem zębatym walcowym o zębach skośnych montowana na kołnierzu z wałem wejściowym  
Shaft input flange-mounted helical gear unit



### **ERCZ..P(IEC)**

Przekładnia B14 z kołem zębatym walcowym o zębach skośnych montowana na kołnierzu  
B14 Flange-mounted helical gear unit



### **ERCZ..HS**

Przekładnia B14 z kołem zębatym walcowym o zębach skośnych montowana na kołnierzu z wałem wejściowym  
Shaft input B14 flange-mounted helical gear unit

### 3. OPIS MODELU / MODEL ILLUMINATE

Przekładnia / Gear unit

Silnik / Motor

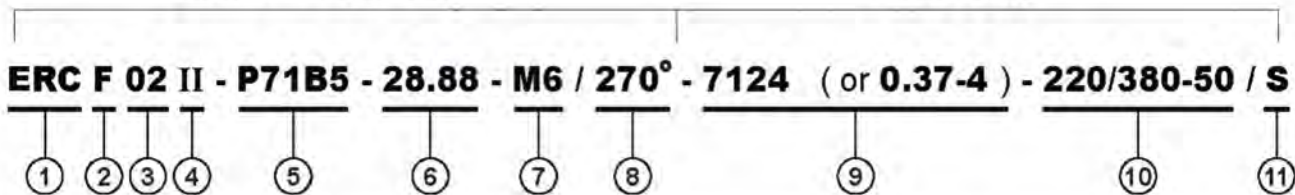

No		Comments
1	ERC: kod danej serii przekładni	ERC: code for gear units series
2	1). Brak kodu oznacza mocowanie na łapach 2). F: B5 mocowanie za pomocą kołnierza 3). Z: B14 mocowanie za pomocą kołnierza	1). No code means foot-mounted 2). F: B5 flange mounted 3). Z: B14 flange mounted
3	Kod specyfikacji przekładni 01,02, 03, 04	Specification code of gear units 01,02,03,04
4	1). B01, M01 ... oznacza kod łap, bez kołnierza 2). I, II, III:B5 Specyfikacja kołnierza wyjściowego, domyślnie dopuszcza się brak podania I	1). B01, M01..... means foot code, without flange 2). I, II, III: B5 Output flange specification, default I not to write out is ok
5	1). IEC: kołnierz wyjściowy 2). HS: wejście wałem	1). IEC input flange 2). HS: Shaft input
6	Przełożenie przekładni I	Transmission ratio of gear units i
7	M1: Położenie montażowe, domyślne położenie montażowe M1 – brak oznaczenia jest dopuszczalny	M1: Mounting position, default mounting position M1 not to write out is ok
8	Schemat położenia skrzynki przyłączeniowej silnika, położenie domyślne 0° (R) - brak oznaczenia jest dopuszczalny	Position diagram for motor terminal box, default position 0°(R) not to write out is ok
9	1). Brak oznaczenia oznacza bez silnika 2). Model silnika (ilość biegunów, moc)	1). No mark means without motor 2). Model motos (poles and power)
10	Napięcie – częstotliwość	Voltage - frequency
11	Cewka w położeniu silnika, położenie domyślne S - brak oznaczenia jest dopuszczalny	Coil in position for motor, default position S not to write out is ok

**Przykład / Example: ERC01B01-P71B5 - 28.50**

**ERCZ03 - HS - 6.31**

**ERCF02III - P80B14- 8.78-7124 -220/380-50 / 2**

Podczas zamawiania należy podać, czy reduktory wyposażone mają zostać w silniki, w innym przypadku, reduktory zostaną dostarczone bez silnika.

When ordering, you should show whether the reducers are equipped with motors. otherwise reducers aren't supplied with motors.

## 4. NAJWAŻNIEJSZE PARAMETRY

### 4.1 Moc P

$$P_1 = \frac{P_2}{\eta} \text{ [kW]}$$

$$P_{1n} \geq P_1 \cdot f_s \text{ [kW]}$$

$P_1$	moc wejściowa
$P_2$	moc wyjściowa
$P_{1n}$	znamionowa moc wejściowa silnika
$f_s$	współczynnik przeciążalności
$\eta$	sprawność

Przekładnie walcowe ERC są dwustopniowe, a ich sprawność wynosi średnio **96%**.

### 4.2 Prędkość obrotowa n

$n_1$	prędkość wejściowa przekładni
$n_2$	prędkość wyjściowa przekładni

W przypadku napędu zewnętrznego, zaleca się prędkość obrotową 1400 obr/min lub mniejszą, by zoptymalizować warunki robocze i przedłużyć okres użytkowania. Możliwe są wyższe prędkości wejściowe, ale w tym przypadku, znamionowy moment  $M_2$  zostanie ograniczony.

### 4.3 Przełożenie i

$$i = \frac{n_1}{n_2}$$

Zazwyczaj, przełożenie jest ułamkiem dziesiętnym do drugiego miejsca po przecinku oznaczonego w tabeli wyborów.

### 4.4 Moment M

$$M_2 = \frac{9550 \cdot P_1 \cdot \eta}{n_2} \text{ [Nm]}$$

$$M_{2n} \geq M_2 \cdot f_s \text{ [Nm]}$$

$M_2$	moment wyjściowy
$M_{2n}$	znamionowy moment wyjściowy
$P_1$	moc wejściowa
$\eta$	sprawność
$f_s$	współczynnik przeciążalności

## 4. RELEVANT PARAMETER

### 4.1 Power P

$$P_1 = \frac{P_2}{\eta} \text{ [kW]}$$

$$P_{1n} \geq P_1 \cdot f_s \text{ [kW]}$$

$P_1$	Input power
$P_2$	Output power
$P_{1n}$	Rated input motor power
$f_s$	Service factor
$\eta$	Transmission efficiency

ERC Series helical gear units has **2 stage** and the efficiency is about **96%**.

### 4.2 Rotation speed n

$n_1$	Gear units input speed
$n_2$	Gear units output speed

If driven by the external gearing, 1400r/min or lower rotation speed is suggested so as to optimize the working conditions and prolong the service life. Higher input rotation speed is permitted, but in this situation, the rated torque  $M_2$  will be reduced.

### 4.3 Transmission ratio i

$$i = \frac{n_1}{n_2}$$

Usually transmission ratio is decimal fraction with 2 radix point tagged in selection tables.

### 4.4 Torque M

$$M_2 = \frac{9550 \cdot P_1 \cdot \eta}{n_2} \text{ [Nm]}$$

$$M_{2n} \geq M_2 \cdot f_s \text{ [Nm]}$$

$M_2$	Output torque
$M_{2n}$	Rated output torque
$P_1$	Input power
$\eta$	Transmission efficiency
$f_s$	Service factor

#### 4.5 Współczynnik przeciążalności $f_s$

Dzięki współczynnikowi przeciążalności  $f_s$  wpływ napędzanej maszyny na przekładnię uwzględniany jest na wystarczającym poziomie dokładności. Współczynnik przeciążalności wyznaczany jest na podstawie codziennego czasu pracy i częstotliwości uruchamiania Z. Uwzględniane są trzy klasyfikacje obciążania w zależności od współczynnika przyspieszenia masy. Z poniższego wykresu odczytać można współczynnik odpowiedni dla Państwa zastosowania. Współczynnik przeciążalności wybrany na podstawie tego wykresu musi być mniejszy od lub równy współczynnikowi podanemu w tabeli parametrów i osiągow.

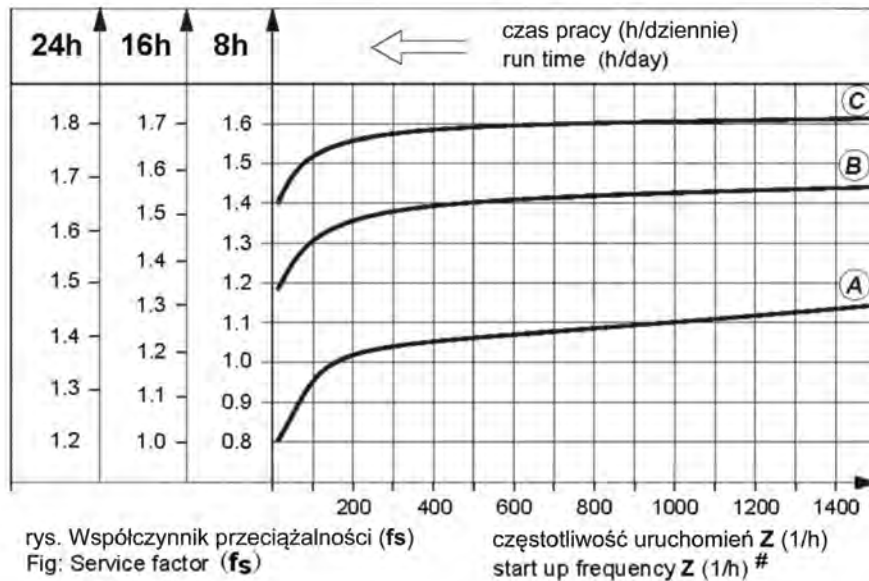

# Częstotliwość uruchomień Z: Cykle obejmują wszystkie procedury uruchamiania i hamowania jak również przełączania z małej do dużej prędkości.

# Starting frequency Z: The cycles include all starting and braking procedures as well as change overs from low to high speed.

##### 4.5.1 Klasyfikacja obciążenia

- (A) Jednolite obciążenie udarowe, dopuszczalny współczynnik przyspieszenia masy  $\leq 0,2$
- (B) Umiarkowane obciążenie udarowe, dopuszczalny współczynnik przyspieszenia masy  $\leq 3$
- (C) Duże obciążenie udarowe, dopuszczalny współczynnik przyspieszenia masy  $\leq 10$

Klasyfikacja obciążeń – patrz załącznik

##### 4.5.1 Load classifications

- (A) Uniformshock load, permitted mass acceleration factor  $\leq 0.2$
- (B) Moderate shock load, permitted mass acceleration factor  $\leq 3$
- (C) Heavy shock load, permitted mass acceleration factor  $\leq 10$

Load classifications see the addendum.

##### 4.5.2 Współczynnik przyspieszenia masy

Współczynnik przyspieszenia masy obliczany jest w następujący sposób:

$$f_a = \frac{J_c}{J_m}$$

##### 4.5.2 Mass acceleration factor

The mass acceleration factor is calculated as follows:

$$f_a = \frac{J_c}{J_m}$$

**fa** współczynnik przyspieszenia masy  
**Jc** wszystkie zewnętrzne momenty bezwładności [kgm<sup>2</sup>]  
**Jm** moment bezwładności ?? silnika [kgm<sup>2</sup>]

Jeżeli współczynniki przyspieszenia masy  $fa > 10$ , prosimy o kontakt z naszym działem technicznym.

By w maksymalnym stopniu przedłużyć żywotność przekładni, współczynnik  $f_s$  wybrany na podstawie katalogu musi być równy lub nieznacznie wyższy od obliczonego współczynnika  $f_s$ .

#### 4.6 Obciążenia promieniowe $F_r$

Wyznaczając wynikowe obciążenia promieniowe, należy wziąć pod uwagę rodzaj elementów przekładni montowanych na końcu wału. Poszczególne elementy przekładni odpowiadają poniższym współczynnikom przekładni  $f_z$ .

Elementy przekładni Transmission element	Współczynnik przekładni $F_z$ Transmission element factor $F_z$	Uwagi Comments
Koła zębate / Gears	1,00	$\geq 17$ zębów
	1,15	$< 17$ zębów
Zębatka koła łańcuchowego / Chain sprockets	1,00	$\geq 20$ zębów
	1,25	$< 20$ zębów
	1,40	$< 13$ zębów
Wąskie koła do paska klinowego / Narrow V-belt pulleys	1,75	Wpływ siły rozciągającej
Koła do pasków płaskich / Flat belt pulleys	2,50	Wpływ siły rozciągającej
Koła do pasków zębatych / Toothed belt pulleys	2,50	Wpływ siły rozciągającej

Obciążenia poprzeczne wywierane na silnik lub wał przekładni oblicza się w następujący sposób:

$$F_r = \frac{M \cdot 2000 \cdot f_z}{d_0} \text{ [N]}$$

**$F_r$**  wynikowa siła poprzeczna [N]  
 **$M$**  moment nawale [Nm]  
 **$d_0$**  średnia średnica zamontowanego elementu przekładni w [mm]  
 **$f_z$**  współczynnik elementu przekładni

Dopuszczalna siła obciążenia poprzecznego na wale obliczana jest na podstawie następującego wzoru:

$$F_{xL} \leq \frac{Fr_2 \cdot a}{(b+x)} \text{ [N]}$$

**$Fr_2$**  Dopuszczalne obciążenie poprzeczne ( $x = L/2$ ) dla jednostek montowany na łapach, zgodnie z tabelami wyboru [N]  
 **$a, b$**  Stała dla przekładni dotycząca konwersji obciążenia poprzecznego [mm]

**fa** Mass acceleration factor  
**Jc** All external mass moments of inertia [kgm<sup>2</sup>]  
**Jm** Mass moment of inertia on the motor end [kgm<sup>2</sup>]

If mass acceleration factors  $fa > 10$ , please call our Technical Service.

To keep the service-life of gear units, the use factor  $f_s$  selected from the catalogue must be equal or slightly higher than the calculated use factor  $f_s$ .

#### 4.6 Radial loads $F_r$

When determining the resulting radial loads, the type of transmission elements, mounted on the shaft end must be considered. Various transmission elements are corresponding with following transmission element factors  $f_z$ :

The overhung loads exerted on the motor or gear shaft is then calculated as follows:

$$F_r = \frac{M \cdot 2000 \cdot f_z}{d_0} \text{ [N]}$$

**$F_r$**  Resulting radial load [N]  
 **$M$**  Torque on the shaft [Nm]  
 **$d_0$**  Mean diameter of the mounted transmission element in [mm]  
 **$f_z$**  Transmission element factor

The allowed radial load force on the shaft is calculated with the following formula:

$$F_{xL} \leq \frac{Fr_2 \cdot a}{(b+x)} \text{ [N]}$$

**$Fr_2$**  Permitted overhung load ( $x = L/2$ ) for foot-mounted gear units according to the selection tables in [N]  
 **$a, b$**  Gear unit constant for overhung load conversion [mm]



x Odległość od stopnia oporowego wału do miejsca przyłożenia siły w [mm]  
Wartości a, b, Fr2 podane są w poniższych tabelach:

x Distance from the shaft shoulder to the force application point in [mm]  
The values of a, b, Fr2 are given in the following tables:

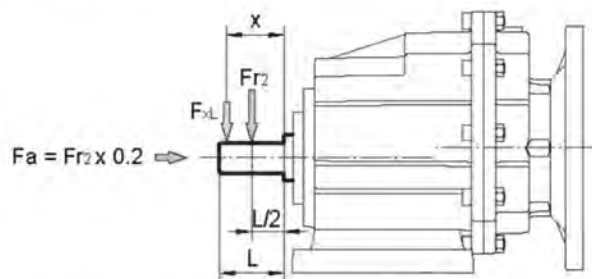

	ERC01	ERC02	ERC03	ERC04
a	103	116.5	130	147
b	83	91.5	100	112

Obciążenia poprzeczne i osiowe Fr1, Fa / Output shafts radial loads & axial loads Fr2, Fa wału zdawczego

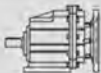
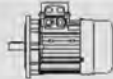

n2 [min <sup>-1</sup> ]		10	40	60	80	100	120	150	180	250	400
Fr2 [N]	ERC01	2500	2500	2180	1980	1840	1630	1400	1320	1080	920
	ERC02	5000	5000	4370	3970	3680	3470	2710	2550	2150	1840
	ERC03	6500	6500	5550	5040	4510	3800	3530	3320	2800	2390
	ERC04	8000	8000	6590	5990	5230	4570	4240	3900	3350	2860

#### 4.7 UWAGI DOTYCZĄCE WYBORU / SELECTION TABLES COMMENTS

P <sub>1n</sub> [kW]	n <sub>2</sub> [r/min]	M <sub>2n</sub> [Nm]	i	f <sub>s</sub>			Page 
----------------------	------------------------	----------------------	---	----------------	--	---	--

 Połączenie kołnierzem IEC **jest możliwe**

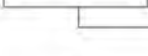
 Połączenie kołnierzem IEC **nie jest możliwe**

**P<sub>1n</sub>** moc znamionowa silnika napędowego [kW]  
**n<sub>2</sub>** prędkość wyjściowa [obr/min]  
**M<sub>2n</sub>** znamionowy moment wyjściowy [Nm]  
**M<sub>2 max</sub>** dopuszczalny moment wyjściowy [Nm]  
**i** przełożenie przekładni  
**f<sub>s</sub>** współczynnik przeciążalności





rodzaj przekładni



rodzaj silnika

page arkusz z wymiarami na stronie nr  
\* przełożenie przekładni

 Combination with the IEC in the header row **is possible**

 Combination with the IEC in the header row **is not possible**

**P<sub>1n</sub>** Rated power of driving motor [kW]  
**n<sub>2</sub>** Output speed [r/min];  
**M<sub>2n</sub>** Rated output torque [Nm];  
**M<sub>2 max</sub>** Permissible output torque [Nm];  
**i** Gear unit ratio;  
**f<sub>s</sub>** Service factor;



Gear unit type;

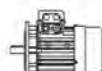

Motor type;

page Dimension sheet page no;  
\* Finite gear unit reduction ratio

## 5. PRZYKŁAD DOBORU / SELECTION EXAMPLE

### 5.1 Przekładnie

Przykład: Wymagany moment na maszynie napędzanej wynosi 400 Nm, maszyna pracuje przez 6 godzin dziennie, jednolite obciążenie udarowe, częstotliwość uruchomień 400 razy na godzinę, kołnierz wyjściowy  $\varnothing$  200 mm,  $n_2 = 30$  obr/min.

Patrz tabele,  $f_s = 1,05$

$$M_{2n} \geq M_2 \cdot f_s = 400 \times 1.05 = 420[\text{Nm}]$$

$$i = \frac{n_1}{n_2} = \frac{1400}{30} = 46.67$$

**ERCF04 II - P90B5 - 44.18**

### 5.2 Motoreduktor

Przykład: Wymagana moc na maszynie napędzanej 1 kW, pracuje 8 godzin dziennie, umiarkowane obciążenie udarowe, rozruch ciągły, mocowanie na łapie M6,  $n_2 = 95$  obr/min.

Patrz tabele,  $f_s = 1,35$

$$i = \frac{n_1}{n_2} = \frac{1400}{95} = 14.74$$

$$P_{1n} \geq P_1 \cdot f_s = \frac{P_2}{\eta} \cdot f_s = \frac{1}{0.96} \times 1.35 = 1.41[\text{kW}]$$

Wybrać typ:

**ERC02 - P90B5 - 14.81 - 1.5-4 - M6**

### 5.1 Gear units

Example: The required torque on driven machine is 400Nm, works for 6 hours per day, Uniform shock load, start-up frequency is 400 times per hour,  $\varnothing$ 200mm output flange-mounted,  $n_2=30$  r/min.

see tables,  $f_s=1.05$

$$M_{2n} \geq M_2 \cdot f_s = 400 \times 1.05 = 420[\text{Nm}]$$

$$i = \frac{n_1}{n_2} = \frac{1400}{30} = 46.67$$

Choose type:

**ERCF04 II - P90B5 - 44.18**

### 5.2 Gear motor

Example: The required power on driven machine 1kW, works for 8 hours per day, moderate shock load, start-up continuously, M6 foot-mounted,  $n_2=95$  r/min.

see tables,  $f_s=1.35$

$$i = \frac{n_1}{n_2} = \frac{1400}{95} = 14.74$$

$$P_{1n} \geq P_1 \cdot f_s = \frac{P_2}{\eta} \cdot f_s = \frac{1}{0.96} \times 1.35 = 1.41[\text{kW}]$$

Choose type:

**ERC02 - P90B5 - 14.81 - 1.5-4 - M6**

## 6. PRZEŁOŻENIE I ADAPTERY SILNIKA IEC

ERC..01..P(IEC)				
i	63B5	71B5 71B14	80B5 80B14	90B5 90B14
53.33				
45.89				
40.10				
35.47				
28.50				
23.56				
19.83				
17.96				
14.62				
13.80*				
11.90				
9.81				
9.17				
7.72				
5.69				
4.63				
3.82				

ERC..02..P(IEC)				
i	63B5	71B5 71B14	80B5 80B14	90B5 90B14
54.00*				
46.46*				
40.60*				
35.91*				
28.88*				
23.85*				
20.08*				
17.10				
14.81*				
13.21				
12.05				
9.93				
8.78				
7.39				
5.45				
4.43				
3.66				

ERC..03..P(IEC)					
i	71B5	80B5 80B14	90B5 90B14	100B5 100B14	112B5 112B14
51.30*					
44.18*					
38.63					
34.20*					
30.57					
24.99					
21.15*					
19.24*					
18.21*					
15.30*					
13.30*					
12.60					
10.93*					
9.08					
7.93*					
6.31					
5.48					
4.50					
3.74					

ERC..04..P(IEC)				
i	80B5 80B14	90B5 90B14	100B5 100B14	112B5 112B14
51.30*				
44.18*				
38.63				
34.20*				
30.57				
24.99				
21.15*				
19.24*				
15.30*				
13.30*				
12.60				
10.93*				
9.08				
7.93*				
6.31				
5.48				
4.50				
3.74				

“\*” Wymiary kołnierzy IEC / Finite gear unit reduction ratio

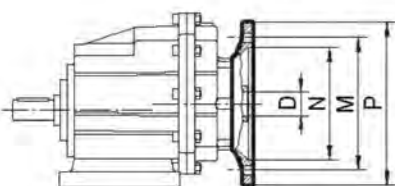

IEC	63B5	71B5	71B14	80B5	80B14	90B5	90B14	100B5	100B14	112B5	112B14
<b>D<sub>ES</sub></b>	11	14		19		24		28		28	
<b>P</b>	140	160	105	200	140	200	140	250	160	250	160
<b>M</b>	115	130	85	165	115	165	115	215	130	215	130
<b>N</b>	95	110	70	130	95	130	95	180	110	180	110

## 7. TABELE DOBORU PRZEKŁADNI / GEAR UNIT SELECTION TABLES

### 7.1 ERC..P(IEC).. Osiągi / Performance parameter

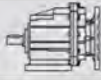
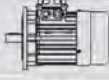
$P_{1n}$ [kW]	$n_2$ [r/min]	$M_{2n}$ [Nm]	$i$	$f_s$			Page	
<b>0.12</b>	26.3	42	53.33	2.9	ERC01	63B5	6314	21
	30.5	36	45.89	3.3	ERCF01	63B5	6314	21
	34.9	32	40.10	3.8	ERCZ01	63B5	6314	21
	39.5	28	35.47	4.3				
	49.1	22	28.50	5.4				
	59.4	18.5	23.56	6.5				
	70.6	15.6	19.83	7.7				
	78.4	14.0	17.86	7.1				
	95.8	11.5	14.62	10.4				
	101	10.8	13.80*	9.2				
	118	9.4	11.90	12.8				
	143	7.7	9.81	13.0				
	153	7.2	9.17	11.1				
	181	6.1	7.72	13.2				
	246	4.5	5.69	13.4				
	302	3.6	4.63	16.5				
366	3.0	3.82	20.0					
<b>0.18</b>	16.9	98	53.33	1.2	ERC01	71B5	7116	21
	19.6	84	45.89	1.4	ERCF01	71B5	7116	21
	22.4	74	40.10	1.6	ERCZ01	71B5	7116	21
	25.4	65	35.47	1.8				
	31.6	52	28.50	2.3				
	26.3	63	53.33	1.9	ERC01	63B5	6324	21
	30.5	54	45.89	2.2	ERCF01	63B5	6324	21
	34.9	47	40.10	2.5	ERCZ01	63B5	6324	21
	39.5	42	35.47	2.9				
	49.1	34	28.50	3.6				
	59.4	28	23.56	4.3				
	70.6	23	19.83	5.1				
	78.4	21	17.86	4.8				
	95.8	17.2	14.62	7.0				
	101	16.3	13.80*	6.1				
	118	14.0	11.90	8.6				
143	11.6	9.81	8.6					
153	10.8	9.17	7.4					
181	9.1	7.72	8.8					
246	6.7	5.69	8.9					
302	5.5	4.63	11.0					
366	4.5	3.82	13.3					
16.7	99	54.00*	2.0	ERC02	71B5	7116	23	
19.4	85	46.46*	2.3	ERCF02	71B5	7116	23	
22.2	74	40.60*	2.7	ERCZ02	71B5	7116	23	
25.1	66	35.91*	3.0					
31.2	53	28.88*	3.8					
25.9	64	54.00*	3.1	ERC02	63B5	6324	23	
30.1	55	46.46*	3.7	ERCF02	63B5	6324	23	
34.5	48	40.60*	4.2	ERCZ02	63B5	6324	23	

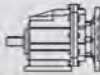
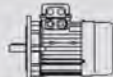
$P_{1n}$ [kW]	$n_2$ [r/min]	$M_{2n}$ [Nm]	$i$	$f_s$			Page	
<b>0.25</b>	16.9	136	53.33	0.88	ERC01	71B5/B14	7126	21
	19.6	117	45.89	1.0	ERCF01	71B5/B14	7126	21
	22.4	102	40.10	1.2	ERCZ01	71B5/B14	7126	21
	25.4	90	35.47	1.3				
	31.6	73	28.50	1.7				
	26.3	87	53.33	1.4	ERC01	71B5/B14	7114	21
	30.5	75	45.89	1.6	ERCF01	71B5/B14	7114	21
	34.9	66	40.10	1.8	ERCZ01	71B5/B14	7114	21
	39.5	58	35.47	2.1				
	49.1	47	28.50	2.6				
	59.4	39	23.56	3.1				
	70.6	32	19.83	3.7				
	78.4	29	17.86	3.4				
	95.8	24	14.62	5.0				
	101	23	13.80*	4.4				
	118	19.5	11.90	6.2				
	143	16.1	9.81	6.2				
	153	15.0	9.17	5.3				
	181	12.6	7.72	6.3				
	246	9.3	5.69	6.4				
	302	7.6	4.63	7.9				
	366	6.3	3.82	9.6				
	16.7	138	54.00*	1.5	ERC02	71B5/B14	7126	23
	19.4	118	46.46*	1.7	ERCF02	71B5/B14	7126	23
	22.2	103	40.60*	1.9	ERCZ02	71B5/B14	7126	23
	25.1	91	35.91*	2.2				
	31.2	74	28.88*	2.7				
	25.9	88	54.00*	2.3	ERC02	71B5/B14	7114	23
	30.1	76	46.46*	2.6	ERCF02	71B5/B14	7114	23
	34.5	66	40.60*	3.0	ERCZ02	71B5/B14	7114	23
	39.0	59	35.91*	3.4				
	48.5	47	28.88*	4.2				
<b>0.37</b>	22.4	151	40.10	0.79	ERC01	80B5/B14	8016	21
	25.4	134	35.47	0.90	ERCF01	80B5/B14	8016	21
	31.6	107	28.50	1.1	ERCZ01	80B5/B14	8016	21
	38.2	89	23.56	1.4				
	26.3	129	53.33	0.93	ERC01	71B5/B14	7124	21
	30.5	111	45.89	1.1	ERCF01	71B5/B14	7124	21
	34.9	97	40.10	1.2	ERCZ01	71B5/B14	7124	21
	39.5	86	35.47	1.4				
	49.1	69	28.50	1.7				
	59.4	57	23.56	2.1				
	70.6	48	19.83	2.5				
	78.4	43	17.86	2.3				
	95.8	35	14.62	3.4				
	101	33	13.80*	3.0				
	118	29	11.90	4.2				
	143	24	9.81	4.2				
	153	22	9.17	3.6				
	181	19	7.72	4.3				
246	14	5.69	4.4					
302	11	4.63	5.3					
366	9	3.82	6.5					

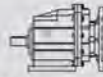
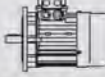
$P_{1n}$ [kW]	$n_2$ [r/min]	$M_{2n}$ [Nm]	$i$	$f_s$			Page		
<b>0.37</b>	16.7	204	54.00*	1.0	ERC02	80B5/B14	8016	23	
	19.4	175	46.46*	1.1	ERCF02	80B5/B14	8016	23	
	22.2	153	40.60*	1.3	ERCZ02	80B5/B14	8016	23	
	25.1	135	35.91*	1.5					
	31.2	109	28.88*	1.8					
	25.9	131	54.00*	1.5	ERC02	71B5/B14	7124	23	
	30.1	113	46.46*	1.8	ERCF02	71B5/B14	7124	23	
	34.5	98	40.60*	2.0	ERCZ02	71B5/B14	7124	23	
	39.0	87	35.91*	2.3					
	48.5	70	28.88*	2.9					
	58.7	58	23.85*	3.5					
	81.9	41	17.10	3.9					
	17.5	193	51.30*	1.6	ERC03	80B5/B14	8016	25	
	20.4	167	44.18*	1.8	ERCF03	80B5/B14	8016	25	
	23.3	146	38.63	2.1	ERCZ03	80B5/B14	8016	25	
	26.3	129	34.20*	2.3					
	29.4	115	30.57	2.6					
	27.3	124	51.30*	2.4	ERC03	71B5	7124	25	
	31.7	107	44.18*	2.8	ERCF03	71B5	7124	25	
	36.2	94	38.63	3.2	ERCZ03	71B5	7124	25	
	40.9	83	34.20*	3.6					
	<b>0.55</b>	31.6	160	28.50	0.75	ERC01	80B5/B14	8026	21
		38.2	132	23.56	0.91	ERCF01	80B5/B14	8026	21
		45.4	111	19.83	1.1	ERCZ01	80B5/B14	8026	21
34.9		144	40.10	0.8	ERC01	80B5/B14	8014	21	
39.5		128	35.47	0.9	ERCF01	80B5/B14	8014	21	
49.1		103	28.50	1.2	ERCZ01	80B5/B14	8014	21	
59.4		85	23.56	1.4					
70.6		71	19.83	1.7					
78.4		64	17.86	1.6					
95.8		53	14.62	2.3					
101		50	13.80*	2.0					
118		43	11.90	2.8					
143		35	9.81	2.8					
153		33	9.17	2.4					
181		28	7.72	2.9					
246		20	5.69	2.9					
302		17	4.63	3.6					
366		14	3.82	4.4					
19.4		260	46.46*	0.77	ERC02	80B5/B14	8026	23	
22.2		227	40.60*	0.88	ERCF02	80B5/B14	8026	23	
25.1		201	35.91*	1.0	ERCZ02	80B5/B14	8026	23	
31.2		162	28.88*	1.2					
37.7		134	23.85*	1.5					
25.9		194	54.00*	1.0	ERC02	80B5/B14	8014	23	
30.1	167	46.46*	1.2	ERCF02	80B5/B14	8014	23		
34.5	146	40.60*	1.4	ERCZ02	80B5/B14	8014	23		
39.0	129	35.91*	1.5						
48.5	104	28.88*	1.9						
58.7	86	23.85*	2.3						

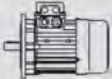
$P_{1n}$ [kW]	$n_2$ [r/min]	$M_{2n}$ [Nm]	$i$	$f_s$			Page	
<b>0.55</b>	69.7	72	20.08*	2.8	ERC02	80B5/B14	8014	23
	81.9	62	17.10	2.6	ERCF02	80B5/B14	8014	23
	94.5	53	14.81*	3.7	ERCZ02	80B5/B14	8014	23
	17.5	287	51.30*	1.0	ERC03	80B5/B14	8026	25
	20.4	248	44.18*	1.2	ERCF03	80B5/B14	8026	25
	23.3	216	38.63	1.4	ERCZ03	80B5/B14	8026	25
	26.3	192	34.20*	1.6				
	29.4	171	30.57	1.8				
	27.3	185	51.30*	1.6	ERC03	80B5/B14	8014	25
	31.7	159	44.18*	1.9	ERCF03	80B5/B14	8014	25
	36.2	139	38.63	2.2	ERCZ03	80B5/B14	8014	25
	40.9	123	34.20*	2.4				
	45.8	110	30.57	2.7				
	56.0	90	24.99	3.3				
	<b>0.75</b>	49.1	140	28.50	0.86	ERC01	80B5/B14	8024
59.4		116	23.56	1.0	ERCF01	80B5/B14	8024	21
70.6		97	19.83	1.2	ERCZ01	80B5/B14	8024	21
78.4		88	17.86	1.1				
95.8		72	14.62	1.7				
101		68	13.80*	1.5				
118		58	11.90	2.1				
143		48	9.81	2.1				
153		45	9.17	1.8				
181		38	7.72	2.1				
246		28	5.69	2.1				
302		23	4.63	2.6				
366		19	3.82	3.2				
31.2		221	28.88*	0.91	ERC02	90B5/B14	90S6	23
37.7		182	23.85*	1.1	ERCF02	90B5/B14	90S6	23
44.8		153	20.08*	1.3	ERCZ02	90B5/B14	90S6	23
30.1		228	46.46*	0.88	ERC02	80B5/B14	8024	23
34.5		199	40.60*	1.0	ERCF02	80B5/B14	8024	23
39.0		176	35.91*	1.1	ERCZ02	80B5/B14	8024	23
48.5		142	28.88*	1.4				
58.7		117	23.85*	1.7				
69.7		99	20.08*	2.0				
81.9		84	17.10	1.9				
94.5		73	14.81*	2.7				
106		65	13.21	2.5				
116.2		59	12.05	3.4				
141		49	9.93	3.3				
159		43	8.78	2.8				
189		36	7.39	3.3				
257		27	5.45	3.7				
97.0		71	28.88*	2.8	ERC02	80B5/B14	8012	23
117.4		59	23.85*	3.4	ERCF02	80B5/B14	8012	23
139.4		49	20.08*	4.1	ERCZ02	80B5/B14	8012	23
163.7		42	17.10	3.8				

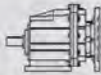
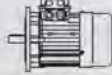
$P_{1n}$ [kW]	$n_2$ [r/min]	$M_{2n}$ [Nm]	$i$	$f_s$			Page		
<b>0.75</b>	17.5	392	51.30*	0.77	ERC03	90B5/B14	90S6	25	
	20.4	338	44.18*	0.89	ERCF03	90B5/B14	90S6	25	
	23.3	295	38.63	1.0	ERCZ03	90B5/B14	90S6	25	
	26.3	261	34.20*	1.1					
	29.4	234	30.57	1.3					
	36.0	191	24.99	1.6					
	27.3	252	51.30*	1.2	ERC03	80B5/B14	8024	25	
	31.7	217	44.18*	1.4	ERCF03	80B5/B14	8024	25	
	36.2	190	38.63	1.6	ERCZ03	80B5/B14	8024	25	
	40.9	168	34.20*	1.8					
	45.8	150	30.57	2.0					
	56.0	123	24.99	2.4					
	66.2	104	21.15*	2.7					
	72.8	94	19.24*	3.0					
	76.9	89	18.21*	3.1					
	91.5	75	15.30*	3.7					
	105	65	13.30*	3.8					
	111	62	12.60	4.0					
	17.5	392	51.30*	1.3	ERC04	90B5/B14	90S6	27	
	20.4	338	44.18*	1.5	ERCF04	90B5/B14	90S6	27	
	23.3	295	38.63	1.7	ERCZ04	90B5/B14	90S6	27	
	26.3	261	34.20*	1.8					
	29.4	234	30.57	2.1					
	27.3	252	51.30*	2.0	ERC04	80B5/B14	8024	27	
	31.7	217	44.18*	2.3	ERCF04	80B5/B14	8024	27	
	36.2	190	38.63	2.6	ERCZ04	80B5/B14	8024	27	
	40.9	168	34.20*	2.9					
	45.8	150	30.57	3.2					
	56.0	123	24.99	3.9					
	66.2	104	21.15*	4.0					
	<b>1.1</b>	70.6	143	19.83	0.84	ERC01	90B5/B14	90S4	21
		78.4	129	17.86	0.78	ERCF01	90B5/B14	90S4	21
		95.8	105	14.62	1.1	ERCZ01	90B5/B14	90S4	21
101		99	13.80*	1.0					
118		86	11.90	1.4					
143		71	9.81	1.4					
153		66	9.17	1.2					
181		56	7.72	1.4					
246		41	5.69	1.5					
302		33	4.63	1.8					
366		28	3.82	2.2					
285		35	9.81	2.8	ERC01	80B5/B14	8022	21	
305		33	9.17	2.4	ERCF01	80B5/B14	8022	21	
363		28	7.72	2.9	ERCZ01	80B5/B14	8022	21	
492		20	5.69	2.9					
605		17	4.63	3.6					
733		14	3.82	4.4					
39.0		259	35.91*	0.77	ERC02	90B5/B14	90S4	23	
48.5		208	28.88*	1.0	ERCF02	90B5/B14	90S4	23	
58.7		172	23.85*	1.2	ERCZ02	90B5/B14	90S4	23	
69.7		145	20.08*	1.4					
81.9		123	17.10	1.3					

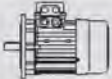

$P_{1n}$ [kW]	$n_2$ [r/min]	$M_{2n}$ [Nm]	$i$	$f_s$			Page	
<b>1.1</b>	94.5	107	14.81*	1.9	ERC02	90B5/B14	90S4	23
	106	95	13.21	1.7	ERCF02	90B5/B14	90S4	23
	116	87	12.05	2.3	ERCZ02	90B5/B14	90S4	23
	141	72	9.93	2.2				
	159	63	8.78	1.9				
	189	53	7.39	2.3				
	257	39	5.45	2.5				
	316	32	4.43	3.1				
	383	26	3.66	3.8				
	27.3	370	51.30*	0.81	ERC03	90B5/B14	90S4	25
	31.7	318	44.18*	0.94	ERCF03	90B5/B14	90S4	25
	36.2	278	38.63	1.1	ERCZ03	90B5/B14	90S4	25
	40.9	246	34.20*	1.2				
	45.8	220	30.57	1.4				
	56.0	180	24.99	1.7				
	66.2	152	21.15*	1.8				
	72.8	139	19.24*	2.0				
	76.9	131	18.21*	2.1				
	91.5	110	15.30*	2.5				
	72.5	139	38.63	2.2	ERC03	80B5/B14	8022	25
	81.9	123	34.20*	2.4	ERCF03	80B5/B14	8022	25
	91.6	110	30.57	2.7	ERCZ03	80B5/B14	8022	25
	112.0	90	24.99	3.3				
	132.4	76	21.15*	3.7				
	145.5	69	19.24*	4.0				
	153.8	66	18.21*	4.3				
	27.3	370	51.30*	1.4	ERC04	90B5/B14	90S4	27
	31.7	318	44.18*	1.6	ERCF04	90B5/B14	90S4	27
	36.2	278	38.63	1.8	ERCZ04	90B5/B14	90S4	27
	40.9	246	34.20*	1.9				
	45.8	220	30.57	2.2				
	56.0	180	24.99	2.7				
	66.2	152	21.15*	2.8				
72.8	139	19.24*	3.0					
76.9	131	18.21*	3.2					
91.5	110	15.30*	3.8					
105	96	13.30*	3.7					
<b>1.5</b>	118	117	11.90	1.0	ERC01	90B5/B14	90L4	21
	143	96	9.81	1.0	ERCF01	90B5/B14	90L4	21
	153	90	9.17	0.9	ERCZ01	90B5/B14	90L4	21
	181	76	7.72	1.1				
	246	56	5.69	1.1				
	302	45	4.63	1.3				
	366	38	3.82	1.6				
	305	45	9.17	1.8	ERC01	90B5/B14	90S2	21
	363	38	7.72	2.1	ERCF01	90B5/B14	90S2	21
	492	28	5.69	2.1	ERCZ01	90B5/B14	90S2	21
	605	23	4.63	2.6				
	733	19	3.82	3.2				

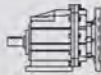
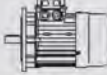

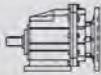
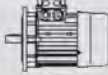
$P_{1n}$ [kW]	$n_2$ [r/min]	$M_{2n}$ [Nm]	$i$	$f_s$			Page	
<b>1.5</b>	58.7	234	23.85*	0.85	ERC02	90B5/B14	90L4	23
	69.7	197	20.08*	1.0	ERCF02	90B5/B14	90L4	23
	81.9	168	17.10	1.0	ERCZ02	90B5/B14	90L4	23
	94.5	145	14.81*	1.4				
	106	130	13.21	1.2				
	116	118	12.05	1.7				
	141	98	9.93	1.6				
	159	86	8.78	1.4				
	189	73	7.39	1.7				
	257	54	5.45	1.9				
	316	44	4.43	2.3				
	383	36	3.66	2.8				
	212	65	13.21	2.5	ERC02	90B5/B14	90S2	23
	232	59	12.05	3.4	ERCF02	90B5/B14	90S2	23
	282	49	9.93	3.3	ERCZ02	90B5/B14	90S2	23
	319	43	8.78	2.8				
	379	36	7.39	3.3				
	514	27	5.45	3.7				
	40.9	336	34.20*	0.89	ERC03	90B5/B14	90L4	25
	45.8	300	30.57	1.0	ERCF03	90B5/B14	90L4	25
	56.0	245	24.99	1.2	ERCZ03	90B5/B14	90L4	25
	66.2	208	21.15*	1.3				
	72.8	189	19.24*	1.5				
	76.9	179	18.21*	1.6				
	91.5	150	15.30*	1.9				
	105	131	13.30*	1.9				
	111	124	12.60	2.0				
128	107	10.93*	1.7					
154	89	9.08	2.0					
177	78	7.93*	2.3					
222	62	6.31	2.9					
255	54	5.48	2.8					
311	44	4.50	3.4					
374	37	3.74	4.1					
256	54	10.93*	3.4	ERC03	90B5/B14	90S2	25	
308	45	9.08	4.0	ERCF03	90B5/B14	90S2	25	
353	39	7.93*	4.6	ERCZ03	90B5/B14	90S2	25	
26.3	523	34.20*	0.92	ERC04	100B5/B14	100L6	27	
29.4	467	30.57	1.0	ERCF04	100B5/B14	100L6	27	
36.0	382	24.99	1.3	ERCZ04	100B5/B14	100L6	27	
27.3	504	51.30*	1.0	ERC04	90B5/B14	90L4	27	
31.7	434	44.18*	1.2	ERCF04	90B5/B14	90L4	27	
36.2	379	38.63	1.3	ERCZ04	90B5/B14	90L4	27	
40.9	336	34.20*	1.4					
45.8	300	30.57	1.6					
56.0	245	24.99	2.0					
66.2	208	21.15*	2.0					
72.8	189	19.24*	2.2					
76.9	179	18.21*	2.3					
91.5	150	15.30*	2.8					
105	131	13.30*	2.7					
111	124	12.60	2.8					
128	107	10.93*	2.6					
154	89	9.08	3.1					
177	78	7.93*	3.3					

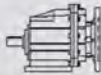
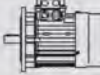
$P_{1n}$ [kW]	$n_2$ [r/min]	$M_{2n}$ [Nm]	$i$	$f_s$			Page		
<b>2.2</b>	72.8	277	19.24*	1.0	ERC03	100B5/B14	100LA4	25	
	91.5	220	15.30*	1.1	ERCF03	100B5/B14	100LA4	25	
	105	192	13.30*	1.3	ERCZ03	100B5/B14	100LA4	25	
	111	182	12.60	1.4					
	128	157	10.93*	1.1					
	154	131	9.08	1.4					
	177	114	7.93*	1.6					
	222	91	6.31	2.0					
	255	79	5.48	1.9					
	311	65	4.50	2.3					
	374	54	3.74	2.8					
	308	65	9.08	2.8	ERC03	90B5/B14	90L2	25	
	353	57	7.93*	3.2	ERCF03	90B5/B14	90L2	25	
	444	45	6.31	4.0	ERCZ03	90B5/B14	90L2	25	
	511	39	5.48	3.8					
	36.0	560	24.99	0.86	ERC04	112B5/B14	112M6	27	
	46.8	431	19.24*	1.0	ERCF04	112B5/B14	112M6	27	
					ERCZ04	112B5/B14	112M6	27	
	40.9	493	34.20*	1.0	ERC04	100B5/B14	100LA4	27	
	45.8	440	30.57	1.1	ERCF04	100B5/B14	100LA4	27	
	56.0	360	24.99	1.3	ERCZ04	100B5/B14	100LA4	27	
	72.8	277	19.24*	1.5					
	91.5	220	15.30*	1.9					
	105	192	13.30*	1.8					
	111	182	12.60	1.9					
	128	157	10.93*	1.8					
	154	131	9.08	2.1					
	177	114	7.93*	2.3					
	222	91	6.31	2.9					
	255	79	5.48	2.9					
	311	65	4.50	3.5					
	374	54	3.74	4.3					
	<b>3</b>	91.5	301	15.30*	0.93	ERC03	100B5/B14	100LB4	25
		105	261	13.30*	1.0	ERCF03	100B5/B14	100LB4	25
		111	248	12.60	1.0	ERCZ03	100B5/B14	100LB4	25
		128	215	10.93*	0.8				
		154	178	9.08	1.0				
		177	156	7.93*	1.2				
		222	124	6.31	1.5				
		255	108	5.48	1.4				
311		88	4.50	1.7					
374		73	3.74	2.0					
45.8		601	30.57	0.80	ERC04	100B5/B14	100LB4	27	
56.0		491	24.99	1.0	ERCF04	100B5/B14	100LB4	27	
72.8		378	19.24*	1.1	ERCZ04	100B5/B14	100LB4	27	
91.5		301	15.30*	1.4					
105		261	13.30*	1.3					
111		248	12.60	1.4					
128		215	10.93*	1.3					
154		178	9.08	1.6					

$P_{1n}$ [kW]	$n_2$ [r/min]	$M_{2n}$ [Nm]	$i$	fs			Page	
<b>3</b>	177	156	7.93*	1.7	ERC04	100B5/B14	100LB4	27
	222	124	6.31	2.1	ERCF04	100B5/B14	100LB4	27
	255	108	5.48	2.1	ERCZ04	100B5/B14	100LB4	27
	311	88	4.50	2.6				
	374	73	3.74	3.1				
	308	89	9.08	3.1	ERC04	100B5/B14	100L2	27
	353	78	7.93*	3.3	ERCF04	100B5/B14	100L2	27
	444	62	6.31	4.2	ERCZ04	100B5/B14	100L2	27
	511	54	5.48	4.3				
<b>4</b>	177	208	7.93*	0.87	ERC03	112B5/B14	112M4	25
	222	165	6.31	1.1	ERCF03	112B5/B14	112M4	25
	255	144	5.48	1.0	ERCZ03	112B5/B14	112M4	25
	311	118	4.50	1.3				
	374	98	3.74	1.5				
	105	348	13.30*	1.0	ERC04	112B5/B14	112M4	27
	111	330	12.60	1.1	ERCF04	112B5/B14	112M4	27
	128	286	10.93*	1.0	ERCZ04	112B5/B14	112M4	27
	154	238	9.08	1.2				
	177	208	7.93*	1.3				
	222	165	6.31	1.6				
	255	144	5.48	1.6				
	311	118	4.50	2.0				
	374	98	3.74	2.3				
	308	119	9.08	2.4	ERC04	112B5/B14	112M2	27
	353	104	7.93*	2.5	ERCF04	112B5/B14	112M2	27
	444	83	6.31	3.1	ERCZ04	112B5/B14	112M2	27
	511	72	5.48	3.2				
	622	59	4.50	3.9				

## 7.2 Parametry przekładni ERC ... HS / Performance parameter

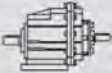
$M_{2max}$ [Nm]	$n_1$ [r/min]	$i$	$P_{1n}$ [kW]	$n_2$ [r/min]		Page
120	1400	53.33	0.34	26.3	<b>ERC01-HS</b>	22
120	1400	45.89	0.40	30.5	<b>ERCF01-HS</b>	22
120	1400	40.10	0.46	34.9	<b>ERCZ01-HS</b>	22
120	1400	35.47	0.52	39.5		
120	1400	28.50	0.64	49.1		
120	1400	23.56	0.78	59.4		
120	1400	19.83	0.92	70.6		
100	1400	17.86	0.86	78.4		
120	1400	14.62	1.25	95.7		
100	1400	13.80 *	1.10	101		
120	1400	11.90	1.54	118		
100	1400	9.81	1.56	143		
80	1400	9.17	1.34	153		
80	1400	7.72	1.58	181		
60	1400	5.69	1.61	246		
60	1400	4.63	1.98	302		
60	1400	3.82	2.40	367		
200	1400	54.00 *	0.57	25.9	<b>ERC02-HS</b>	24
200	1400	46.46 *	0.66	30.1	<b>ERCF02-HS</b>	24
200	1400	40.60 *	0.75	34.5	<b>ERCZ02-HS</b>	24
200	1400	35.91 *	0.85	39.0		
200	1400	28.88 *	1.06	48.5		
200	1400	23.85 *	1.28	58.7		
200	1400	20.08 *	1.52	69.7		
160	1400	17.10	1.43	81.9		
200	1400	14.81 *	2.06	94.6		
160	1400	13.21	1.85	106		
200	1400	12.05	2.53	116		
160	1400	9.93	2.46	141		
120	1400	8.78	2.08	159		
120	1400	7.39	2.49	190		
100	1400	5.45	2.80	257		
100	1400	4.43	3.45	316		
100	1400	3.66	4.18	383		

$M_{2max}$ [Nm]	$n_1$ [r/min]	$i$	$P_{1n}$ [kW]	$n_2$ [r/min]		Page 
300	1400	51.30 *	0.89	27.3	<b>ERC03-HS</b>	26
300	1400	44.18 *	1.04	31.7	<b>ERCF03-HS</b>	26
300	1400	38.63	1.19	36.2	<b>ERCZ03-HS</b>	26
300	1400	34.20 *	1.34	40.9		
300	1400	30.57	1.50	45.8		
300	1400	24.99	1.83	56.0		
280	1400	21.15 *	2.02	66.2		
280	1400	19.24 *	2.22	72.8		
250	1400	18.21 *	2.10	76.9		
280	1400	15.30 *	2.79	91.5		
250	1400	13.30 *	2.86	105		
250	1400	12.60	3.03	111		
180	1400	10.93	2.51	128		
180	1400	9.08	3.02	154		
180	1400	7.93 *	3.46	176		
180	1400	6.31	4.36	222		
150	1400	5.48	4.17	255		
150	1400	4.50	5.09	311		
150	1400	3.74	6.12	374		
500	1400	51.30 *	1.49	27.3	<b>ERC04-HS</b>	28
500	1400	44.18 *	1.73	31.7	<b>ERCF04-HS</b>	28
500	1400	38.63	1.98	36.2	<b>ERCZ04-HS</b>	28
480	1400	34.20 *	2.14	40.9		
480	1400	30.57	2.40	45.8		
480	1400	24.99	2.93	56.0		
280	1400	21.15 *	2.02	66.2		
420	1400	19.24 *	3.34	72.8		
420	1400	15.30 *	4.19	91.5		
350	1400	13.30 *	4.01	105		
350	1400	12.60	4.24	111		
280	1400	10.93	3.91	128		
280	1400	9.08	4.70	154		
260	1400	7.93 *	4.99	176		
260	1400	6.31	6.30	222		
230	1400	5.48	6.40	255		
230	1400	4.50	7.80	311		
230	1400	3.74	9.38	374		

## 8. KARTA WYMIARÓW MONTAŻOWYCH I GABARYTOWYCH / OUTLINE DIMENSION SHEET

### ERC01..P(IEC)

WEJŚCIE / INPUT

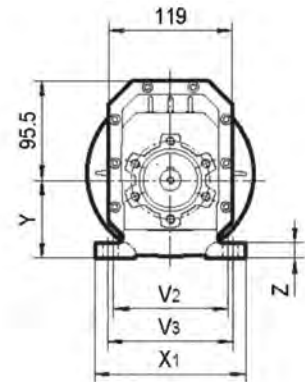
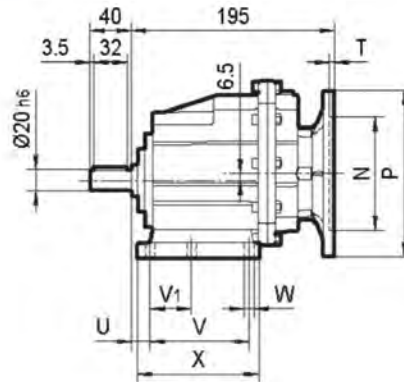
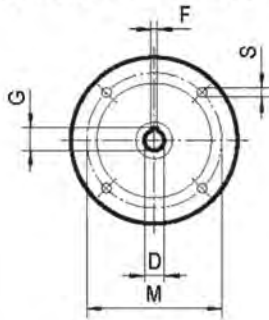

### ERCF01..P(IEC)

WYJŚCIE / OUTPUT

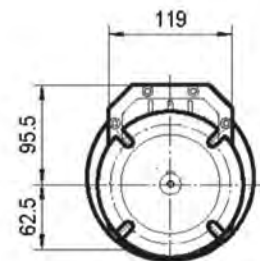
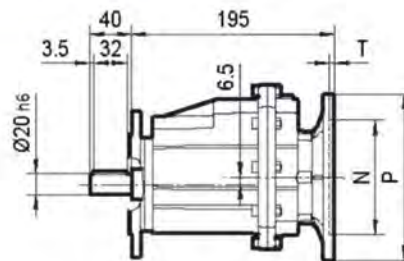
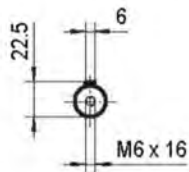

I

Ø120

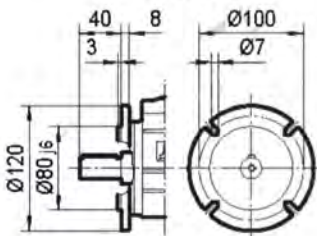

II

Ø140

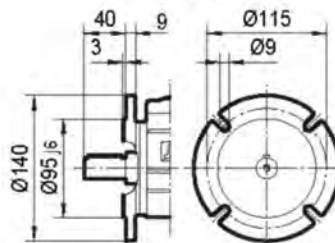

III

Ø160

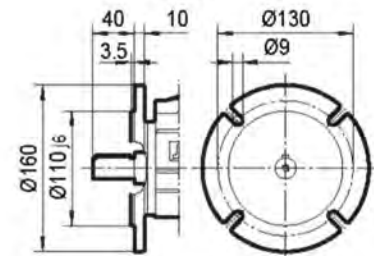

### ERCZ01..P(IEC)

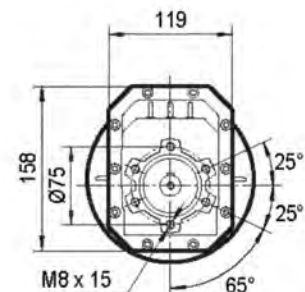
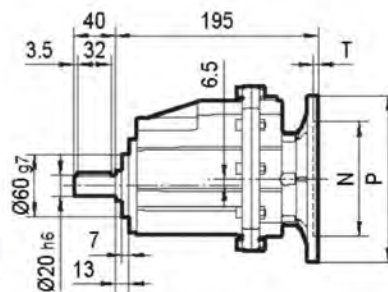

IEC	D	F	G	P	M	N	S	T
63B5	11	4	12.8	140	115	95	9	4
71B5	14	5	16.3	160	130	110	9	4
71B14	14	5	16.3	105	85	70	7	4
80B5	19	6	21.8	200	165	130	11	4
80B14	19	6	21.8	120	100	80	7	4
90B5	24	8	27.3	200	165	130	11	4
90B14	24	8	27.3	140	115	95	9	4

Oznaczenie montażu / Foot code	U	V	V1	V2	V3	W	X	X1	Y	Z
B01	18	87	50	110	—	9	118	130	85	15
M01	18	80	—	110	120	9	118	145	75	15
M02	25	85	—	110	120	9	112	145	75	15
B02	18	107.5	60	—	130	11	136	155	95	17

## ERC01..HS

WEJŚCIE / INPUT

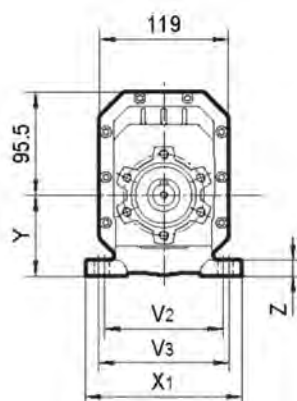
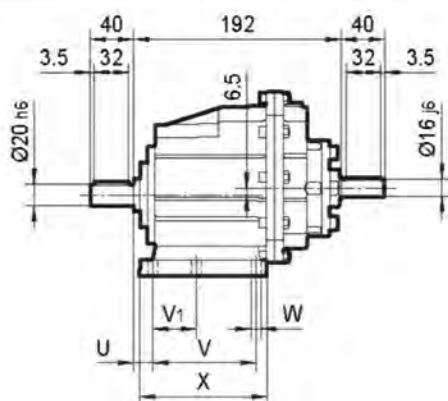
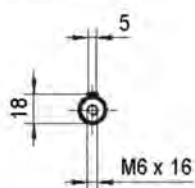

## ERCF01..HS

WYJŚCIE / OUTPUT

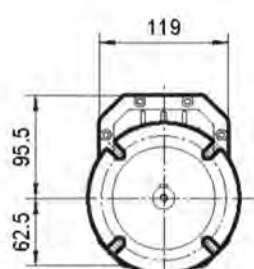
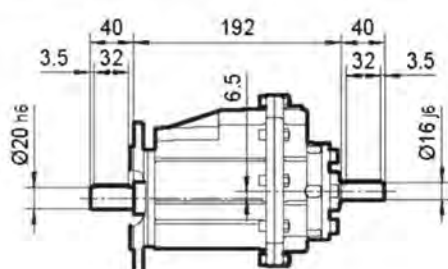
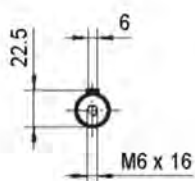

**I**  
**Ø120**

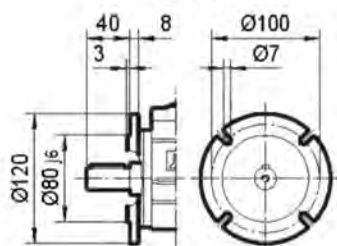

**II**  
**Ø140**

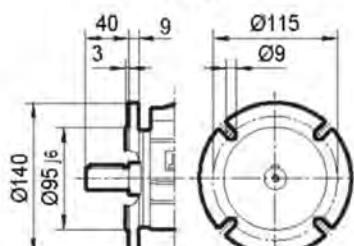

**III**  
**Ø160**

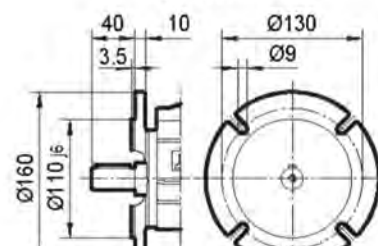

## ERCZ01..HS

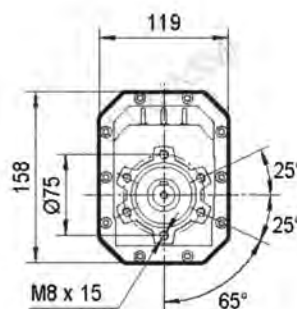
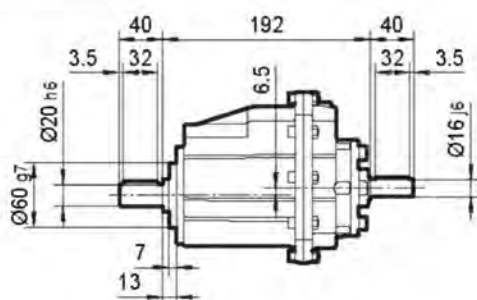

Oznaczenie montażu / Foot code	U	V	V1	V2	V3	W	X	X1	Y	Z
B01	18	87	50	110	—	9	118	130	85	15
M01	18	80	—	110	120	9	118	145	75	15
M02	25	85	—	110	120	9	112	145	75	15
B02	18	107.5	60	—	130	11	136	155	95	17



## ERC02..P(IEC)

WEJŚCIE / INPUT

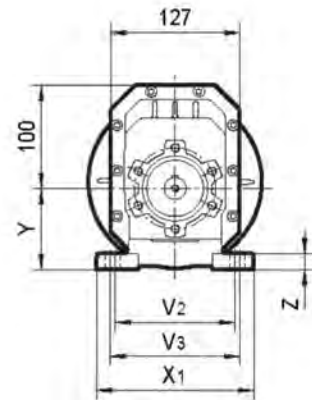
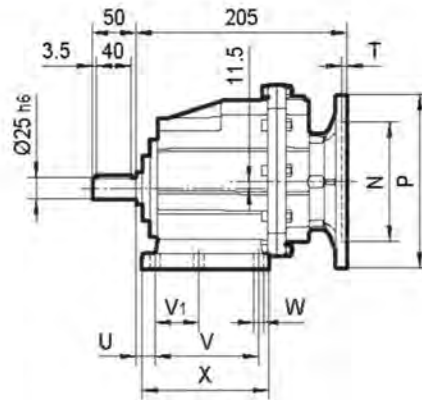
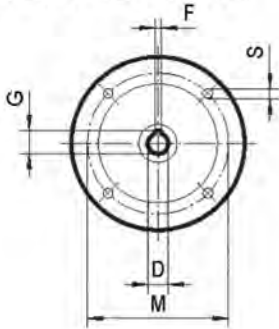

## ERCF02..P(IEC)

WYJŚCIE / OUTPUT

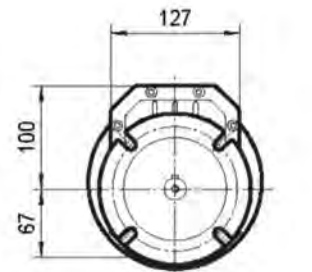
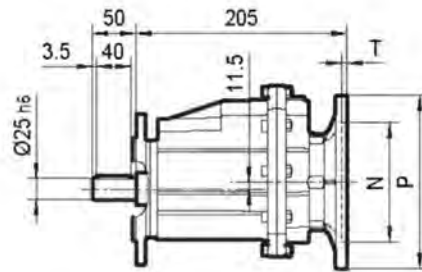
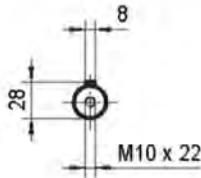

**I**  
**Ø140**

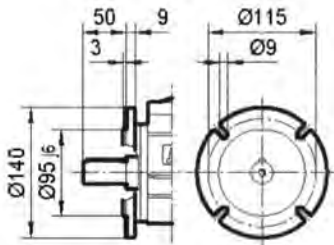

**II**  
**Ø160**

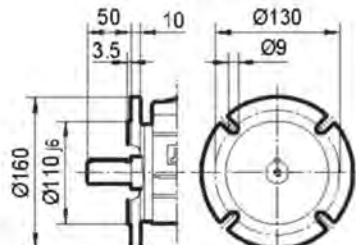

**III**  
**Ø200**

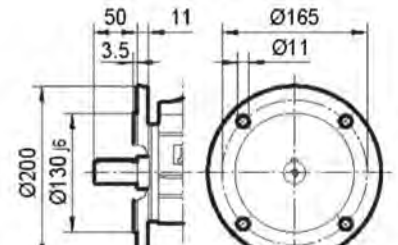

## ERCZ02..P(IEC)

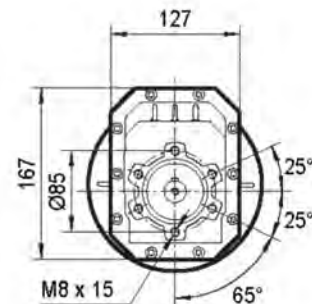
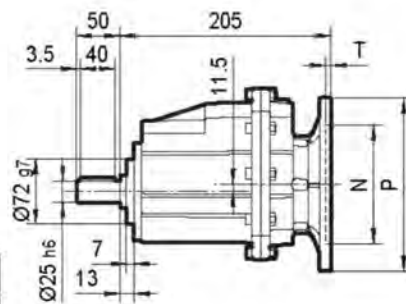

IEC	D	F	G	P	M	N	S	T
63B5	11	4	12.8	140	115	95	9	4
71B5	14	5	16.3	160	130	110	9	4
71B14	14	5	16.3	105	85	70	7	4
80B5	19	6	21.8	200	165	130	11	4
80B14	19	6	21.8	120	100	80	7	4
90B5	24	8	27.3	200	165	130	11	4
90B14	24	8	27.3	140	115	95	9	4

Oznaczenie montażu / Foot code	U	V	V1	V2	V3	W	X	X1	Y	Z
B02	18	107.5	60	—	130	11	136	155	100	17
M02	25	85	—	110	120	9	112	145	80	15
M01	18	80	—	110	120	9	118	145	80	15
B01	18	87	50	110	—	9	118	130	90	15

## ERC02..HS

### WEJŚCIE / INPUT

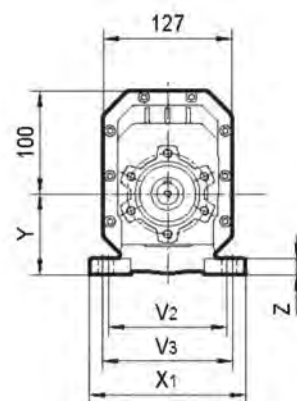
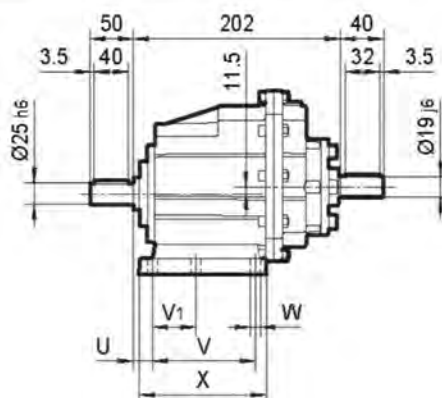
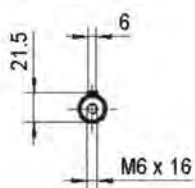

## ERCF02..HS

### WYJŚCIE / OUTPUT

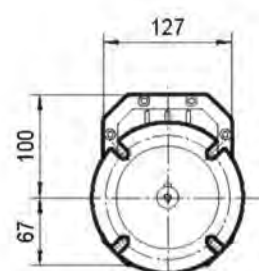
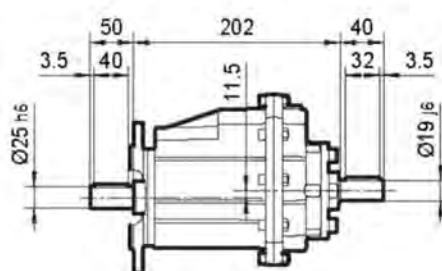
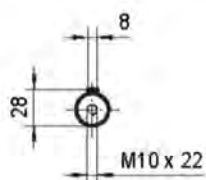

#### I Ø140

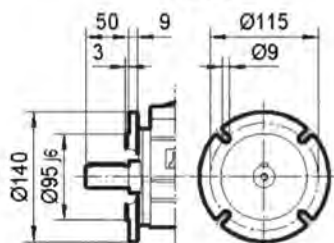

#### II Ø160

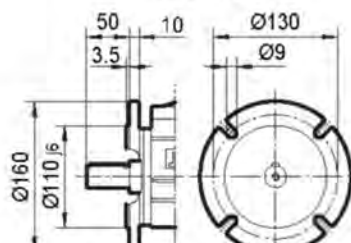

#### III Ø200

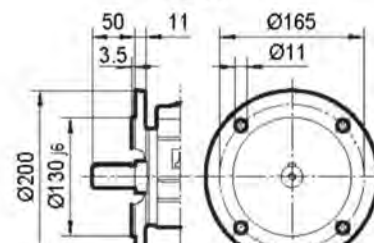

## ERCZ02..HS

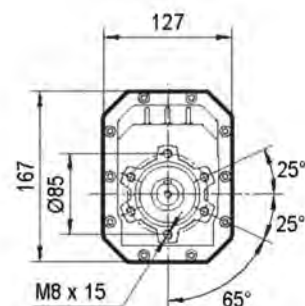
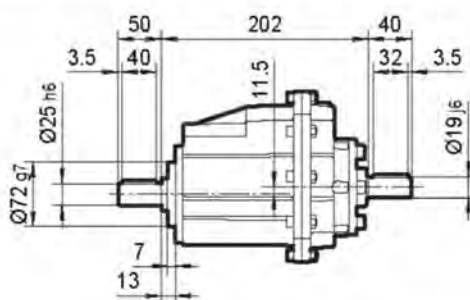

Oznaczenie montażu / Foot code	U	V	V1	V2	V3	W	X	X1	Y	Z
B02	18	107.5	60	—	130	11	136	155	100	17
M02	25	85	—	110	120	9	112	145	80	15
M01	18	80	—	110	120	9	118	145	80	15
B01	18	87	50	110	—	9	118	130	90	15

## ERC03..P(IEC)

WEJŚCIE / INPUT

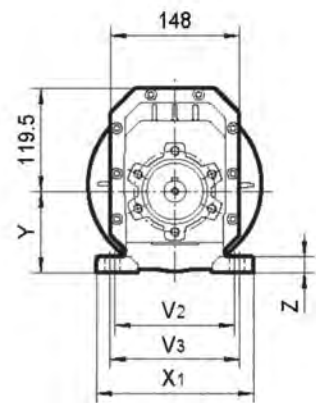
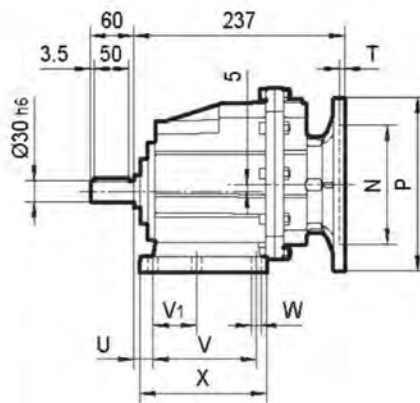
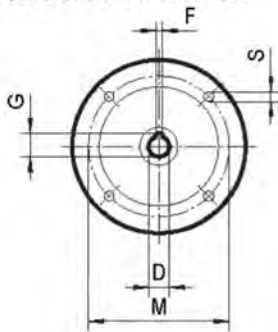

## ERCF03..P(IEC)

WYJŚCIE / OUTPUT

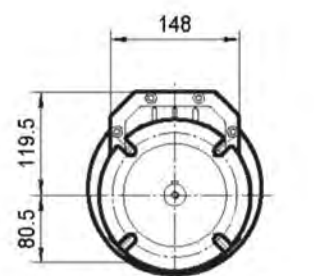
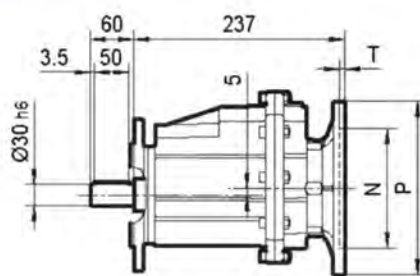
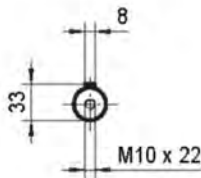

**I**  
**Ø160**

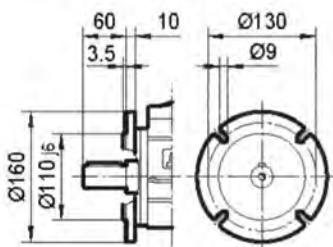

**II**  
**Ø200**

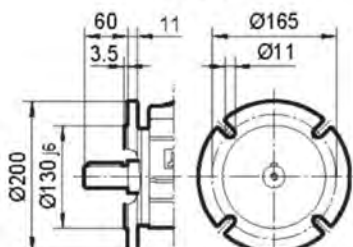

**III**  
**Ø250**

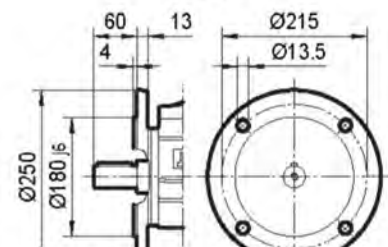

## ERCZ03..P(IEC)

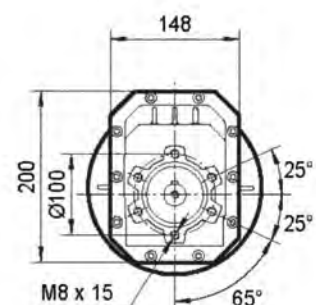
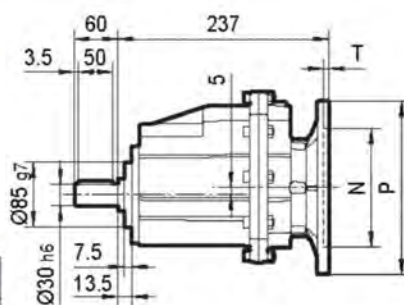

IEC	D	F	G	P	M	N	S	T
71B5	14	5	16.3	160	130	110	9	4
80B5	19	6	21.8	200	165	130	11	4
80B14	19	6	21.8	120	100	80	7	4
90B5	24	8	27.3	200	165	130	11	4
90B14	24	8	27.3	140	115	95	9	4
100/112B5	28	8	31.3	250	215	180	13.5	4.5
100/112B14	28	8	31.3	160	130	110	9	4.5

Oznaczenie montażu / Foot code	U	V	V1	V2	V3	W	X	X1	Y	Z
B03	18	130	70	—	160	11	156	190	110	20
M03	30	100	—	135	150	11	150	190	110	18
M04	32	110	—	170	185	14	150	230	110	20
B04	20.5	130	—	170	—	14	168	205	105	20

## ERC03..HS

WEJŚCIE / INPUT

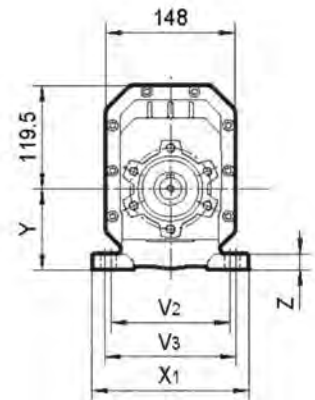
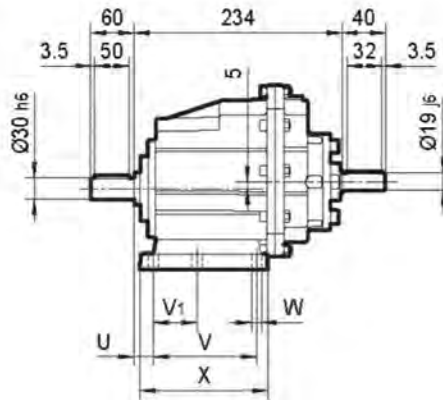
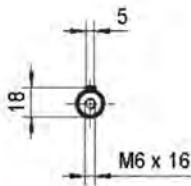

## ERCF03..HS

WYJŚCIE / OUTPUT

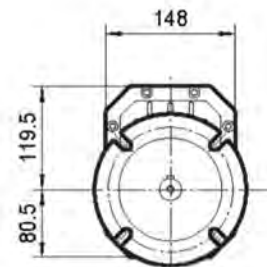
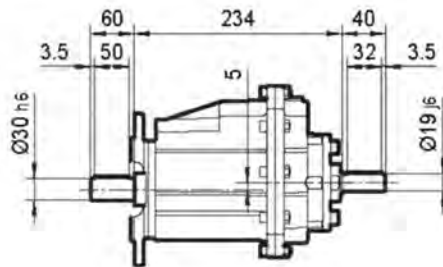
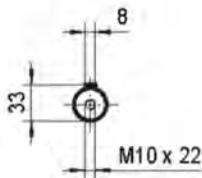

I

Ø160

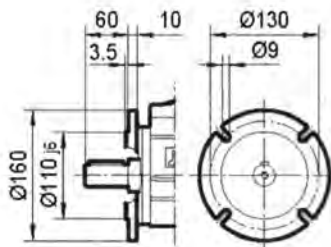

II

Ø200

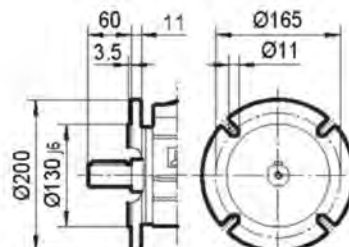

III

Ø250

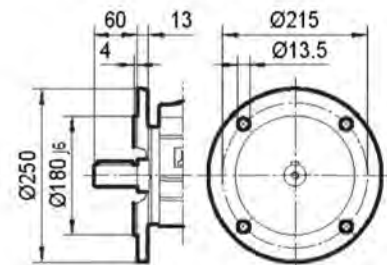

## ERCZ03..HS

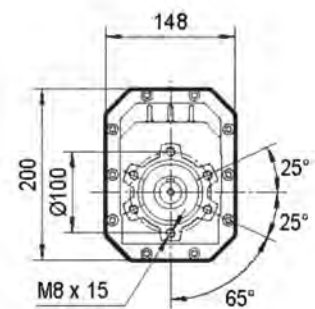
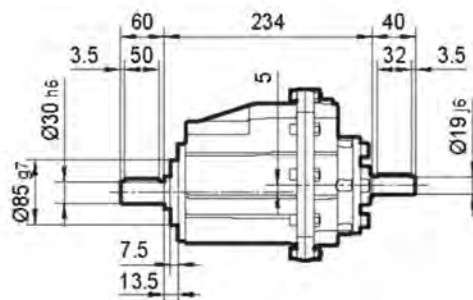

Oznaczenie montażu / Foot code	U	V	V1	V2	V3	W	X	X1	Y	Z
<b>B03</b>	18	130	70	—	160	11	156	190	110	20
<b>M03</b>	30	100	—	135	150	11	150	190	110	18
<b>M04</b>	32	110	—	170	185	14	150	230	110	20
<b>B04</b>	20.5	130	—	170	—	14	168	205	105	20

## ERC04..P(IEC)

WEJŚCIE / INPUT

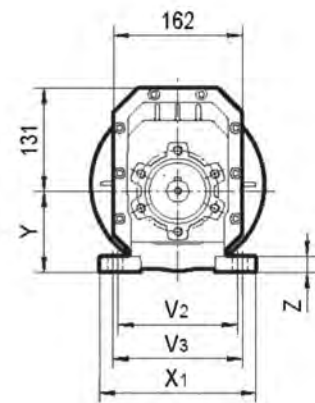
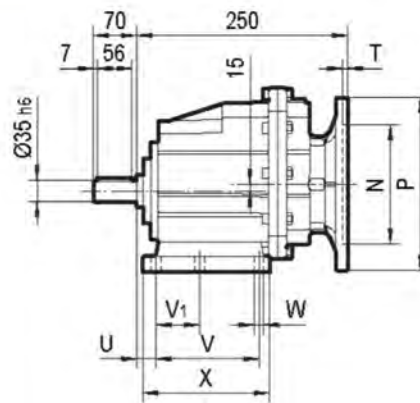
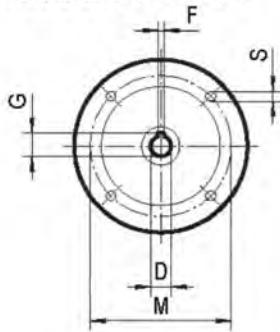

## ERCF04..P(IEC)

WYJŚCIE / OUTPUT

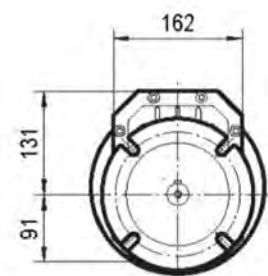
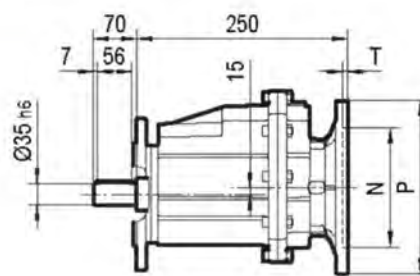
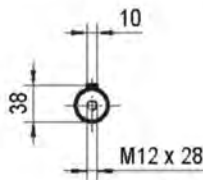

**I**  
Ø160

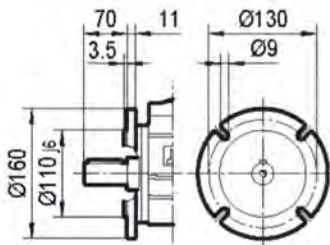

**II**  
Ø200

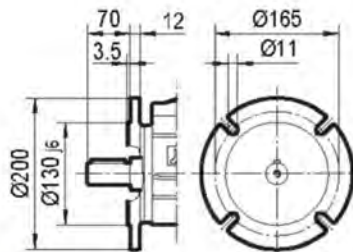

**III**  
Ø250

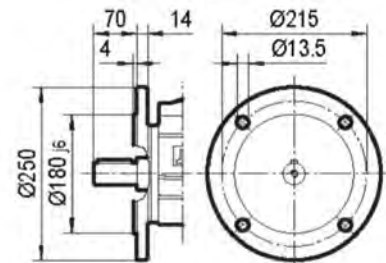

## ERCZ04..P(IEC)

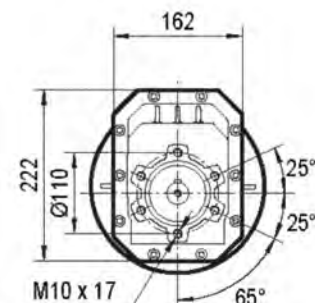
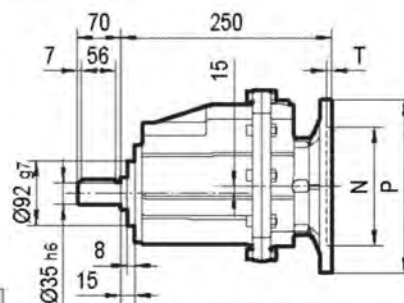

IEC	D	F	G	P	M	N	S	T
80B5	19	6	21.8	200	165	130	11	4
80B14	19	6	21.8	120	100	80	7	4
90B5	24	8	27.3	200	165	130	11	4
90B14	24	8	27.3	140	115	95	9	4
100/112B5	28	8	31.3	250	215	180	13.5	4.5
100/112B14	28	8	31.3	160	130	110	9	4.5

Oznaczenie montażu / Fasti code	U	V	V <sub>1</sub>	V <sub>2</sub>	V <sub>3</sub>	W	X	X <sub>1</sub>	Y	Z
B04	23.5	130	—	170	—	14	168	205	115	20
B05	19.5	149.5	—	180	—	14	185	215	130	20
M04	35	110	—	170	185	14	150	230	120	20
M03	33	100	—	135	150	11	150	190	120	18
B03	21	130	70	—	160	11	156	190	120	20

## ERC04..HS

WEJŚCIE / INPUT

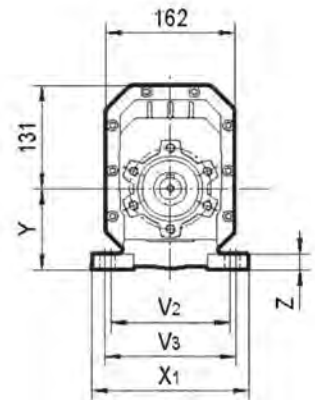
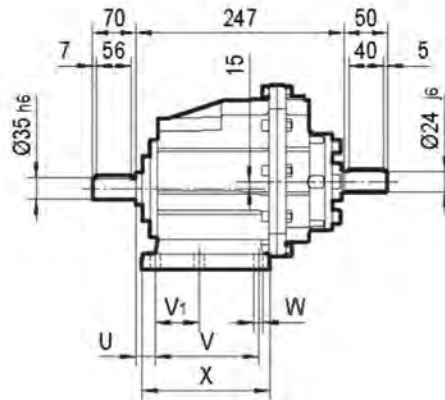
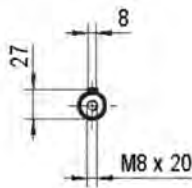

## ERCF04..HS

WYJŚCIE / OUTPUT

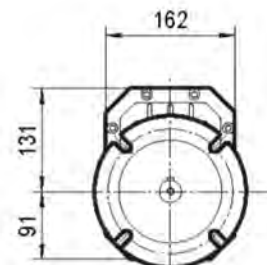
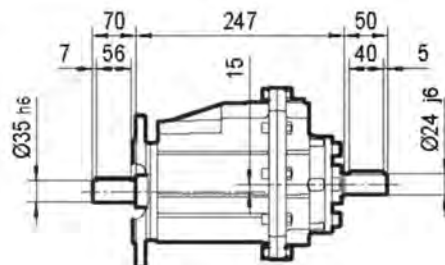
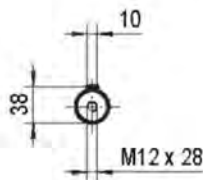

I

Ø160

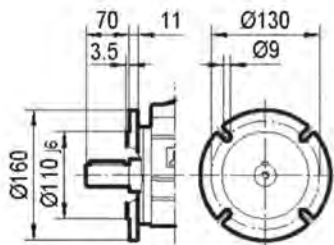

II

Ø200

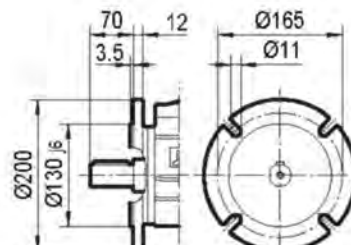

III

Ø250

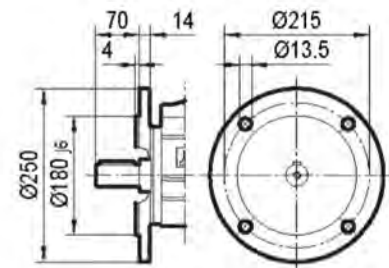

## ERCZ04..HS

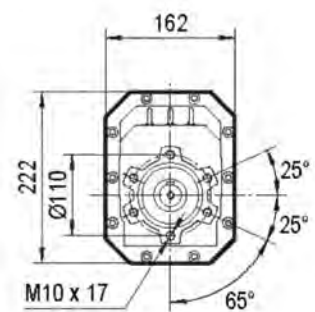
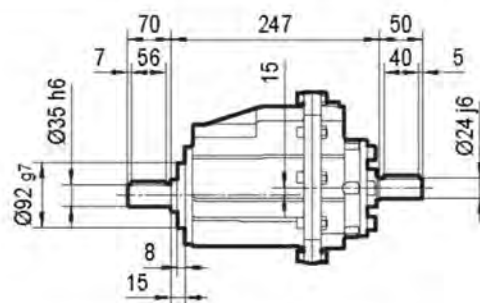

Oznaczenie montażu / Foot code	U	V	V1	V2	V3	W	X	X1	Y	Z
B04	23.5	130	—	170	—	14	168	205	115	20
B05	19.5	149.5	—	180	—	14	185	215	130	20
M04	35	110	—	170	185	14	150	230	120	20
M03	33	100	—	135	150	11	150	190	120	18
B03	21	130	70	—	160	11	156	190	120	20

## 9. POŁOŻENIA MONTAŻOWE I USTAWIENIE SKRZYNKI ZACISKOWEJ / MOUNTING POSITION AND TERMINAL BOX ORIENTATION

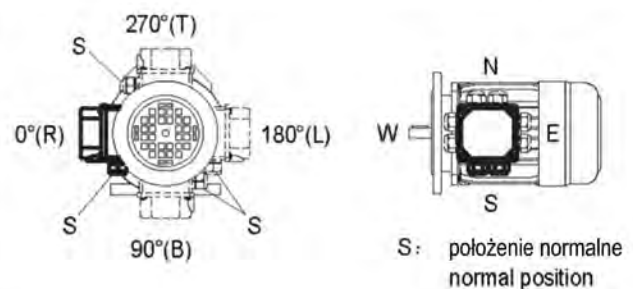
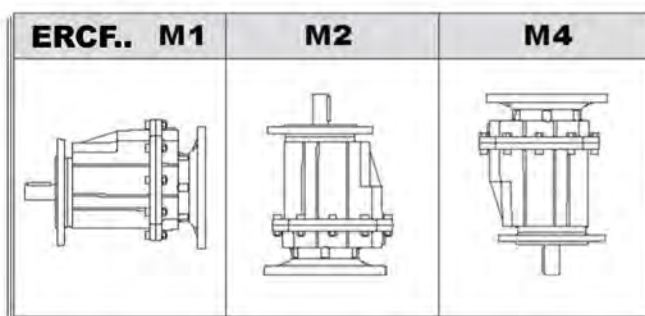
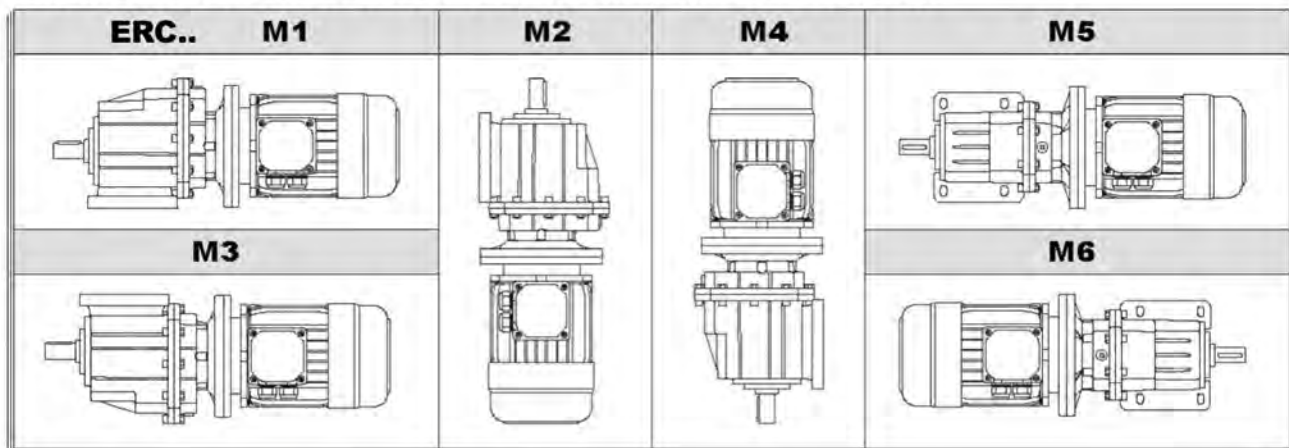

## 10. SMAROWANIE / LUBRICATION

### 10.1 Informacje ogólne

W przypadku normalnych rozwiązań, firma PROMOTOR dostarcza napędy napelnione środkiem smarującym dostosowanym do danej przekładni i położenia montażowego. Czynnikiem decydującym jest położenie montażowe (M1 ... M6, Rozdział „Położenia montażowe i istotne informacje podczas zamawiania”) określone podczas zamawiania napędu. W przypadku położenia przekładni, innego niż w/w należy dostosować do niego ilość środka smarującego.

### 10.2 Smary do łożysk tocznych

Na kolejnej stronie podane zostały środki smarujące dopuszczone do przekładni PROMOTOR. Poniżej podany został opis korzystania z tabeli:

### 10.1 General information

Unless a special arrangement is made, PROMOTOR supplies the drives with a lubricant fill adapted for the specific gear unit and mounting position. The decisive factor is the mounting position (M1 ... M6, → Sec. "Mounting Positions and Important Order Information") specified when ordering the drive. You must adapt the lubricant fill in case of any subsequent changes made to the mounting position (→ Lubricant fill quantities).

### 10.2 Anti-friction bearing greases

The lubricant table on the following page shows the permitted lubricants for PROMOTOR gear units. Please note the following key to the lubricant table:

-20°C ~ +60°C	Mobil	Mobilux EP 2
-40°C ~ +80°C	Mobil	Mobiltemp SHC 100
-20°C ~ +80°C	Esso	Unirex EQ3
-20°C ~ +60°C	Shell	Alvania RL3
-45°C ~ +25°C	Shell	Aero Shell Grease 16

Wymagane są następujące ilości smaru:

- Łożyska szybkobieżne (strona wejściowa silnika i przekładni): wypełnić smarem do jednej trzeciej wolnej przestrzeni.

- Łożyska wolnobieżne (wewnątrz przekładni i na wyjściu z przekładni): wypełnić smarem do dwóch trzecich wolnej przestrzeni.





Łożyska zamknięte - nie ma konieczności smarowania.

The following grease quantities are required:

- For fast-running bearings (motor and gear unit input end): Fill the cavities between the rolling elements one third full with grease.

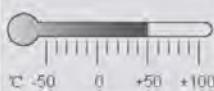
- For slow-running bearings (in gear units and at gear unit output end): Fill the cavities between the rolling elements two thirds full with grease.

### 10.3 Rodzaje smarów / Types of lubrication

						Typ smarowania / lubrication type
<b>ERC</b>	标准 / Standard -10      +40	VG 220	Shell Omala 220	Mobilgear 630	BP Energol GR-XP 220	Olej mineralny Mineral oil
	-20      +25	VG 150 VG 100	Shell Omala 100	Mobilgear 627	BP Energol GR-XP 100	
	-30      +10	VG 68-46 VG 32	Shell Tellus T 32	Mobil D.T.E. 13M		
	-40      -20	VG 22 VG 15	Shell Tellus T 15	Mobil D.T.E. 11M	BP Energol HLP-HM 15	
	-40      +60	VG 220	Shell Omala HD 220	Mobil SHC 630		Olej syntetyczny Synthetic oil
	-40      -40	VG 150	Shell Omala HD 150	Mobil SHC 629		
	-40      +10	VG 32		Mobil SHC 624		

### 10.4 Ilość środka smarującego / Lubricant fill quantity

Typ przekładni Gear units	Ilość oleju podana w litrach / Fill quantity in liters						Jednostka [l] / unit (L)	
	M1	M2	M3	M4	M5	M6		
ERC..01..	0.4	0.6	0.4	0.3	0.3	0.3		
ERC..02..	0.5	0.7	0.5	0.4	0.4	0.4		
ERC..03..	0.8	1.1	0.8	0.6	0.6	0.6		
ERC..04..	1.2	1.6	1.0	1.0	0.9	0.9		

Ilość zalania podana w tabeli odnosi się dokładnie do przełożenia. Wszystkie przekładnie o zębach skośnych wypełniane są dożywotnio przed dostawą i nie ma konieczności wymiany środka smarującego.

The fill quantity in the table is referenced, the exact value relating to the ratio. All ERC Series helical gear units are filled with life lubrication before delivery, do not need to change it in general.



## **11. METODY MONTAŻU / INSTALLATION METHODS**

### **11.1 Przygotowanie przed montażem**

1). Sprawdzić, czy dane na tabliczce znamionowej silnika motoreduktora odpowiadają wartościom sieci zasilania.

2). W przypadku standardowych przekładni, temperatura otoczenia musi odpowiadać wartościom podanym w tabeli smarów.

3). Napędu nie wolno montować w środowisku, w którym unoszą się opary oleju, kwasu, w którym obecny jest gaz, promieniowanie, itp.

4). Powierzchnie wału zdawczego i kołnierza muszą być dokładnie wyczyszczone, aby nie nosiły śladów środka antykorozyjnego, zabrudzeń, itp. Wykorzystać można powszechnie dostępne środki. Nie dopuścić do tego, by rozpuszczalnik zetknął się z uszczelką, w innym przypadku może dojść do uszkodzenia materiału.

5). Konstrukcja wsporcza musi posiadać następującą charakterystykę: poziom, tłumienie drgań i sztywność skrętną.

### **11.2 Montaż jednostek przekładni**

1). Nie należy dokręcać łap obudowy i kołnierzy mocujących do siebie i upewnić się, że dopuszczalne siły poprzeczne i osiowe nie zostały przekroczone.

2). Kół pasowych, łączników, wałków zębatych, itp. nigdy nie należy nakładać na końcówkę wału uderzając w nie młotkiem. Doprowadzi to do uszkodzenia łożyska, obudowy i wału.

3). Przed uruchomieniem, sprawdzić, czy poziom oleju znajduje się na prawidłowym poziomie dla danego położenia montażowego. Sprawdzić, czy śruba spustowa i zawory odpowietrzające są łatwo dostępne.

### **11.1 Preparation before the installation**

1). Check if the data on the nameplates of the gearmotor matches the voltage supply system.

2). For standard gear unit, the ambient temperature must be in accordance with the corresponding lubricant table.

3). The drive must not be assembled in conditions such as oil, gas, vapors, acids, radiation and so on.

4). Output shaft and flange surfaces must be thoroughly cleaned to ensure they are free of anti-corrosion agents, contamination or similar. Use a commercially available solvent. Do not let the solvent come into contact with the sealing lip of the oil seals, or will damage the material!

5). The supporting structure must have the following characteristics: level, vibration damping and torsionally rigid.

### **11.2 The installation of the gear units**

1). Do not tighten the housing legs and mounting flanges against one another and ensure that you comply with the permitted radial load and axial load.

2). Never drive belt pulleys, couplings, pinions, etc. onto the shaft end by hitting them with a hammer. This will damage the bearing, housing and the shaft.

3). Prior to startup, check that if the oil level is as specified for the mounting position. If the oil checking and drain screw and the breather valves are free accessible.

## 12. NAPRAWA USTEREK / CORRECT THE MALFUNCTION

Problem	Możliwa przyczyna	Środki naprawcze
Nietypowy, regularny hałas podczas pracy	A. Hałasy zazębienia: Uszkodzone łożysko B. Stuki: Nieprawidłowa praca kół zębatach	A. Sprawdzić olej, wymienić łożyska B. Skontaktować się ze sprzedawcą
Nietypowy, regularny hałas podczas pracy	Materiał obcy w oleju	• Sprawdzić olej • Zatrzymać napęd, skontaktować się ze sprzedawcą
Wyciek oleju <sup>1)</sup> - z osłony przekładni - z kołnierza silnika - z uszczelki olejowej na silniku - z kołnierza przekładni - z uszczelki olejowej na końcu zdawczym	A. Gumowa uszczelka na osłonie nieszczelna B. Wadliwa uszczelka C. Przekładnia nieodpowietrzona	A. Dokręcić śruby na osłonie przekładni i obserwować przekładnię. Olej nadal wycieka: skontaktować się ze sprzedawcą B. Skontaktować się ze sprzedawcą C. Odpowietrzyć przekładnię (patrz „Położenia montażowe”)
Olej wycieka z odpowietrznika	A. Zbyt dużo oleju B. Napęd obsługiwany w nieprawidłowym położeniu C. Częste rozruchy na zimno (pienienie oleju) i / lub zbyt wysoki poziom oleju	A. Zapewnić prawidłowy poziom oleju (patrz rozdział „Kontrola i konserwacja”) B. Zamontować prawidłowo zawór odpowietrzający (patrz rozdział „Położenia montażowe”) i skorygować poziom oleju (patrz „Smary”)
Wał zdawczy nie obraca się pomimo tego, że silnik pracuje lub wał wejściowy obraca się.	Brak połączenia pomiędzy wałem a piastą w przekładni	Przesłać przekładnię / motoreduktor do naprawy

1) Niewielki wyciek z okolic uszczelnień możliwy w okresie 24 godzin od uruchomienia

Problem	Possible cause	Remedy
Unusual, regular running noise	A. Meshing/grinding noise: Bearing damage. B. Knocking noise: Irregularity in the gearing	A. Check the oil, change bearings B. Contact customer service
Unusual, irregular running noise	Foreign bodies in the oil	• Check the oil • Stop the drive, contact customer service
Oil leaking <sup>1)</sup> • From the gear cover plate • From the motor flange • From the motor oil seal • From the gear unit flange • From the output end oil seal	A. Rubber seal on the gear cover plate leaking B. Seal defective C. Gear unit not vented	A. Tighten the bolts on the gear cover plate and observe the gear unit. Oil still leaking: Contact customer service B. Contact customer service C. Vent the gear unit (see "Mounting Positions")
Oil leaking from breaking valve	A. Too much oil B. Drive operated in incorrect mounting position C. Frequent cold starts(oil foams) and/or high oillevel	A. Correct the oil level (see Sec. "Inspection and Maintenance") B. Mount the breather valve correctly (see Sec."Mounting Positions")and correct the oil level(see"Lubricants")
Output shaft does not turn although the motor is running or the input shaft is rotated	Connection between shaft and hub in gear unit interrupted	Send in the gear unit/gearmotor for repair

1) Short-term oil/grease leakage at the oil seal is possible in the run-in phase (24 hours running time).

13. KARTA CHARAKTERYSTYKI (DO INFORMACJI)  
CHARGE CHARACTERISTIC CHART (FOR REFERENCE)

<b>DMUCHAWY POWIETRZA / AIR BLOWERS</b>		Zespół przekładni podnośnika / Hoist gear assembly	A
Dmuchawy powietrza / Air blower (axial or radial)	A	Zespół przekładni Derrick / Derrick gear assembly	B
Wentylator wieży chłodniczej / Fan of cooling tower	B	Zespół przekładni sterowania / Steering gear assembly	B
Wentylator ciągu / Induced draught fan	B	Zespół przekładni / Moving gear assembly	C
Wentylator z tłokiem obrotowym / Rotary piston type fan	B	<b>POGŁĘBIARKI LĄDOWE / LAND DREDGER</b>	
Turbo-wentylator / Turbo-fan	A	Przenośnik bębnowy / Drum-type conveyer	C
<b>MASZYNY BUDOWLANE / CONSTRUCTION MACHINERY</b>		Koło obrotowe bębnowe / Drum-type rotation wheel	C
Mieszalnik betonu / Concrete mixer	B	Głowica pogłębiania / Dredger head	C
Wciągarnik / Hoist	B	Dźwig mechaniczny / Powered crab	B
Maszyny do budowy dróg / Road buildings	B	Pompa / Pump	B
Tokarka karuzelowa / Boring mill	B	Zespół obracarki / Pump turning gear assembly	B
<b>MASZYNY CHEMICZNE / CHEMICAL MACHINERY</b>		Zespół przekładni (koło osłonowe) / Moving gear assembly (apron wheel)	C
Mieszalnik (płynny) / Mixer (liquid)	A	Zespół przekładni (gąsienica) / Moving gear assembly (track)	B
Mieszalnik (pół-płynny) / Mixer (half liquid)	B	<b>MASZYNY PRZETWÓRSTWA PRODUKTÓW SPOŻYWCZYCH FOODSTUFF PROCESSING MACHINERY</b>	
Wirówka (ciężka) / Centrifuge (heavy)	B	Pakowarka / Placer od box filler	A
Wirówka (lekka) / Centrifuge (light)	A	Zgniatacz puszek / Cane crusher	A
** Chłodzący bęben obrotowy / ** Cooling rolling drum	B	** Nożyce do puszek / **Cane cutter	B
** Suszący bęben obrotowy / ** Dry rolling drum	B	** Zgniatacz puszek / **Cane crusher	C
Mieszadło / Mixer	B	Mieszadło / Mixer	B
<b>SPRĘŻARKA / COMPRESSOR</b>		Kosz na pastę / Kosz na pastę	B
Sprężarka tłokowa / Piston type compressor	C	Pakowaczka / Packager	A
Turbosprężarka / Turbo-compressor	B	Nóż do buraków / Beet slicer	B
<b>PRZENOŚNIK / TRANSMISSION FREIGHTER</b>		Maszyna do mycia buraków / Beet washing machine	B
Przenośnik płytowy / Pan conveyer	B	<b>SILNIK I SPRZĘT PRZEKŁADNIOWY / MOTOR AND CONVERSION EQUIPMENTS</b>	
Podnośnik balansowy / Balance lifter	B	Przetwornica częstotliwości / Frequency converter	C
Przenośnik rynnowy / Trough conveyer	B	Silnik / Motor	C
Przenośnik pasowy (duży) / Ribbon conveyer (large piece)	C	Silnik spawalniczy / Welding motor	C
Przenośnik pasowy (mały) / Ribbon conveyer (small piece)	B	<b>PRALKA / WASHING MACHINE</b>	
Przenośnik bębnowy / Drum-type flour conveyer	A	Bęben obrotowy / Rolling drum	B
Przenośnik łańcuchowy / Chain conveyer	B	Pralka / Washing machine	B
Przenośnik pierścieniowy / Ring type conveyer	B	<b>WALCARKA METALU / METAL ROLLER MACHINE</b>	
Podnośnik / Lifter	B	** Nożyce do stali / ** Steel cutter	C
Wciągarka / Hoist	B	** Przenośnik łańcuchowy / ** Chain conveyer	B
Przenośnik korbowy / Crank-connecting conveyer	B	** Walcarka na zimno / ** Cold mill	C
Podnośnik / Lifter	B	Sprzęt do lania ciągłego / Continuous casting equipments	B
Przenośnik ślimakowy / Worm conveyer	B	** Łoże zimne / ** Cold bed	B
Przenośnik z taśmą stalową / Steel-band conveyer	B	** Obcinarka / ** Cropper	C
Przenośnik łańcuchowy / Chain reed-type conveyer	B	** Nadajnik sterowania krzyżowego / ** Cross steering transmitter	B
Przenośnik chwytakowy / Crab freighter	B	** Odrdzewiacz / ** Deruster	C
<b>WCIĄGNIK / HOIST</b>		** Walcownia ciężka i średnia / ** Heavy and medium steel mill	C
Zespół wahacza wspornika / Bracket swing gear assembly	B	** Walcowania prętów / ** Bar mill	C

SPRZĘT DO TRANSPORTU PRĘTÓW / BAR TRANSMISSION EQUIPMENTS	B	POMPY / PUMPS	
Popychacz do prętów / Bar pusher	B	Pompa odśrodkowa (płyn o małej gęstości) / Centrifugal pump (thin liquid)	A
Łoże popychacza / Push bes	B	Pompa odśrodkowa (płyn o dużej gęstości) / Centrifugal pump (half liquid)	B
** Nożyce / ** Shears	C	Pompa wyporowa / Displacement pump	C
** Platforma podnośnikowa / ** Lumber elevator platform	B	Pompa numikowa / Plunger pump	C
WYPOSAŻENIE DO REGULACJI WALCÓW / ROLL ADJUSTING EQUIPMENTS	B	Pompa tłoczna / Force pump	C
Maszyna poziomowania walców / Roller leveling machine	B	SPRZĘT DO TWORZYW SZTUCZNYCH / PLASTIC EQUIPMENTS	
** Bieżnia do walcowania (ciężka) / Mill rolling way (heavy)	C	** Prasa do paneli z tworzyw sztucznych / ** Glazing press	B
** Bieżnia do walcowania (lekka) / Mill rolling way (light)	B	** Prasa wyściowa / ** Ejecting press	B
** Walce do blachy / Sheet rolling mill	C	** Spiralna maszyna do tłoczenia / ** Spiral extruding machine	B
** Nożyce do cięcia / Trimming shears	B	** Maszyna do mieszania / ** Mixing machine	B
Spawarka do rur / Pipe welder	C	SPRZĘT DO GUMY / RUBBER EQUIPMENT	
Maszyna do lutowania (pasy i drutówka) / Soldering machine (belt material and wire rod)	B	** Prasa do paneli z tworzyw sztucznych / ** Glazing press	B
Ciągadło do drutu / Wire drawbench	B	** Prasa wyściowa / ** Ejecting press	C
NARZĘDZIA DO OBRÓBK METALU / METAL PROCESSING MACHINE TOOLS		** Maszyna do mieszania / ** Mixing stir machine	B
Wał napędowy / Power shaft	A	Maszyna do zagniatania / Kneading machine	B
** Maszyna do kucia / ** Forging machine	C	** Maszyna do walcowania / ** Roller machine	C
Młot / Drop hammer	C	SPRZĘT DO PRZETWARZANIA KAMIENI, PORCELANY I GLINY / STONE PORCELAIN CLAY PROCESSING EQUIPMENTS	
Oprządowanie maszyny / Machine tool and necessary	A	Kruszarka do kul / Ball crusher	B
Oprządowanie maszyny i główny sprzęt napędowy / Machine tool and main driving equipment	B	** Prasa wyściowa i przerywacz / ** Ejecting press and breaker	C
Maszyna do planowania metalu / Metal facing machine	C	Przerywacz / Breaker	C
Maszyna do poziomowania płyt / Plate-leveling machine tool	C	Prasa do kostek / Brick press	C
Przebijarka / Backing-out punch	C	** Kruszarka / ** Beating crusher	C
Narzędzie do prasy / Press machine tool	C	** Przetwornica / ** Converter	C
Maszyna do cięcia / Cutting machine	B	** Walec cylindryczny / ** Cylinder mill	C
Narzędzie do giętarki blach / Sheet bending machine tool	B	MASZYNY DO TEKSTYLIÓW / TEXTILE MACHINERY	
MASZYNY DO PRZETWARZANIA ROPY NAFTOWEJ / PETROLEUM PROCESSING MACHINERY		Maszyna podająca / Feeding machine	B
** Pompa do rurociągów / ** Pump of oil pipe line	B	Krosno / Loom machine	B
Obrotowy sprzęt wiertniczy / Rotary drilling equipment	C	Maszyna do barwienia / Dyeing machine	B
MASZYNY PAPIERNICZE / PAPERING MACHINE		Bęben oczyszczający / purified drum	B
** Prasa do powlekania / ** Glazing press	C	Maszyna do firan / Welon machine	B
** Maszyna do kartonu wielowarstwowego / ** Multilayer paper board machine	C	SPRZĘT DO UZDATNIANIA ŚCIEKÓW / WASTER TREATMENT EQUIPMENTS	
** Cylinder suszący / ** Drying cylinder	C	** Dmuchawa powietrza / ** Air blast	B
** Cylinder do powlekania / ** Glazing cylinder	C	Pompa ślimakowa / Screw pump	B
** Ubijak / ** Masher	C	NARZĘDZIA DO MASZYN DO PRZETWÓRSTWA DREWNA / WOOD PROCESSING MACHINE TOOL	
** Maszyna do ubijania i rozbijania / ** Mashing and breaking machine	C	Obieraczka / Baker	C
** Walec ssący / ** Suction roll	C	Maszyna do licowania / Facing machine	B
** Walcarka mokrego papieru / ** Wet paper roller machine	C	Piła stołowa / Saw bench	C
** Walec absorbujący wodę / ** Water absorbing roller machine	C	Narzędzia do maszyn do przetwórstwa drewna / Wood processing machine tool	A
Maszyna rozwałcowania / Welon machine	C		

Uwaga: A – obciążenie jednolite, B – obciążenie udarowe umiarkowane, C – obciążenie udarowe ciężkie; \*\* - do systemu 24 godzinnego

Note: A - Uniform load; B - Moderate shock load; C - Heavy shock load; \*\* - for 24hour system.