

QUICK SELECTION / Selezione veloce

input speed (n₁) = 1400 min⁻¹

Output Speed n ₂ [min ⁻¹]	Ratio i	Motor power P _{1M} [kW]	Output torque M _{2M} [Nm]	Service factor f.s.	Nominal power P _{1R} [kW]	Nominal torque M _{2R} [Nm]	Available B5 motor flanges					Available B14 motor flanges				Output Shaft		
							-C	-D	-E	-F	-G	-R	-T	-U	-V			Ratios code
							71	80	90	100 112	132*	80	90	100 112	132	3018	3016	
388	3.61	7.5	171	1.1	8.0	190	B											01
331	4.23	7.5	200	1.1	8.3	230	B											02
279	5.01	7.5	238	1.1	7.9	260	B											03
231	6.07	7.5	288	1.1	7.8	310	B											04
206	6.81	7.5	323	1.1	7.9	350	B											05
176	7.96	7.5	378	1.0	7.1	370	B											07
148	9.45	5.5	331	1.2	6.6	410	B											08
122	11.43	5.5	401	1.1	5.7	425	B											09
100	14.00	4	359	1.2	4.7	435	B											10
84	16.62	4	426	1.2	4.7	515	B											11
70	20.10	4	515	1.0	4.0	530	B											12
57	24.61	3	475	1.1	3.3	530	B											20
47.6	29.41	2.2	418	1.1	2.3	450	B											14
39.3	35.58	2.2	506	1.0	2.3	530	B											15
34.6	40.50	1.1	290	1.1	1.2	320	B											16
31.7	44.23	1.5	433	0.9	1.4	410	B											17
28.6	49.00	1.1	351	1.1	1.2	400	B											18
23.0	60.90	1.1	436	0.9	1.0	410	B											19

The dynamic efficiency is **0.96** for all ratios *Nel montaggio P la flangia può superare l'ingombro massimo dei piedi. Eventualmente utilizzare la flangia B14
* In the P mounting the B5 motor flange can exceed the foot maximum dimensions. Possibly use the flange B14

- A) Motor Flanges Available**
Flange Motore Disponibili
- B) Supplied with Reduction Bushing**
Fornito con Bussola di Riduzione
- B) Available on Request without reduction bushing**
Disponibile a Richiesta senza Bussola di Riduzione
- C) Motor Flange Holes Position**
Posizione Fori Flangia Motore

EN Unit **612A** is supplied with synthetic oil for lifetime lubrication, no maintenance is necessary.
See table 1 for lubrication and recommended quantity.
In table 2 please see possible radial loads and axial loads on the gearbox.

I Il riduttore **612A** viene fornito completo di olio sintetico per la lubrificazione permanente e non necessita di alcuna manutenzione.
Vedi tab.1 per oli e quantità consigliati.
In tab.2 sono presenti i carichi radiali e assiali applicabili al riduttore.

D Das Getriebe **612A** ist mit synthetischem Öl gefüllt und ist lebensdauergeschmiert.
In Tabelle 1 ist die Schmiermenge und das empfohlene Schmiermittel angegeben.
In Tabelle 2 sind die zulässigen Radial - und Axialbelastungen des Getriebes aufgeführt.

F Le réducteur **612A** est fourni complet avec de l'huile synthétique pour la lubrification permanente et ne nécessite aucun entretien.
Voir tableau 1 concernant les huiles et les quantités conseillées.
Les charges radiales et axiales applicables au réducteur sont précisées dans le tableau 2.

E El reductor tamaño **612A** se suministra, lubricado de por vida con aceite sintético y no requieren mantenimiento alguna.
Ver tabla 1, para cantidades y aceites recomendados.
En la tabla 2, se encuentran las cargas radiales y axiales admitidas por el reductor.

Standard supplied	For these mounting position specify in the order or add oil Per queste posizioni specificare in fase d'ordine o aggiungere olio						
0.80 LT	1.00 LT	1.20 LT	1.20 LT	1.30 LT	1.35 LT	Ask	
SHELL Omala S4 WE 320				ENI Telium VSF 320			

For all details on lubrication and plugs check our website **tab. 1**
Per maggiori dettagli su lubrificazione e tappi olio vedi il nostro sito web

RADIAL AND AXIAL LOADS								
Output shaft Albero di uscita			F_{eq} = F_R $\frac{60.5}{X+25.5}$					
n ₂	FA	FR	n ₂	FA	FR	n ₂	FA	FR
300	560	2800	140	740	3700	70	890	4200
250	600	3000	120	760	3800	40	1160	5800
200	640	3200	85	840	4000	15	1300	6500
Input shaft Albero in entrata								
n ₁	FA	FR						
1400	450	2250						
900	500	2500						
500	600	3000						

tab. 2

P612A **B1**... With feet
Con piedini

Gearbox weight **14.1 kg**
peso riduttore With feet **14.5 kg**

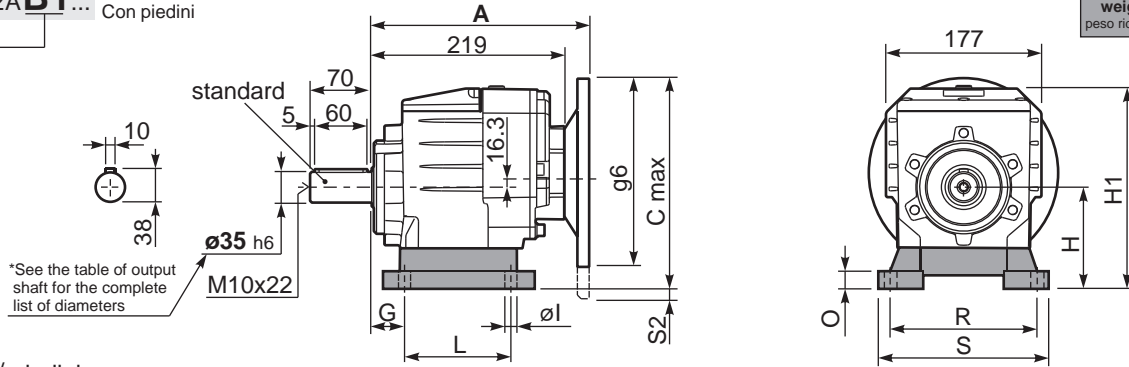

Feet / piedini

Feet Code	Market reference	G	H	R	L	S	H1	O	øl	S2 only with motor flange	B5 max. Flange	kit code
B4	412/3	20	130	180	149.5	216	242	18	14	-	-	KC60.9.024
S4	47-57	30	115	135	165	170	227	25	14	13 132B5	-	KC50.9.022
M3	62/3	35	120	170-185	110	230	232	20	14	8 132B5	-	KC60.9.023
S7	77	35	140	170	205	204	252	8	14	-	-	KC60.9.029LM
H4	024-243	35	155	170	150	225	267	30	14	-	-	KC60.9.025

Other feet are available, see our web site
Sono disponibili altri piedini, consulta il nostro sito web

A see on page bottom

Most popular types
Tipi più diffusi

P612A-**F**... Output flanges
flange di uscita

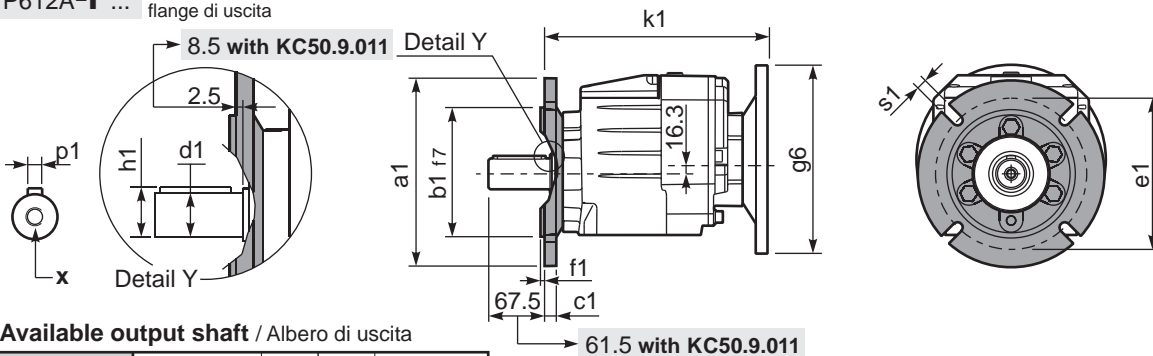

*Available output shaft / Alberi di uscita

	Shaft - d1	p1	h1	x
Standard	ø 35x70	10	38	M10x22
On request A richiesta	ø 28x60	8	31	M8x20
	ø 30x60	8	33	M10x22
	ø 38x70	10	41	M10x25
	ø 40x80	12	43	M12x28

Available output flanges / flange di uscita

a1 ø	b1	c1	e1	f1	s1	kit code
160	110	14	130	3.5	11	KC50.9.011
200	130	13	165	3.5	11	KC50.9.012
250	180	15.5	215	4	14	KC50.9.013

With flange and feet only on request.
Ask for compatibility

P612A-**N**... Basic gearbox
Riduttore base

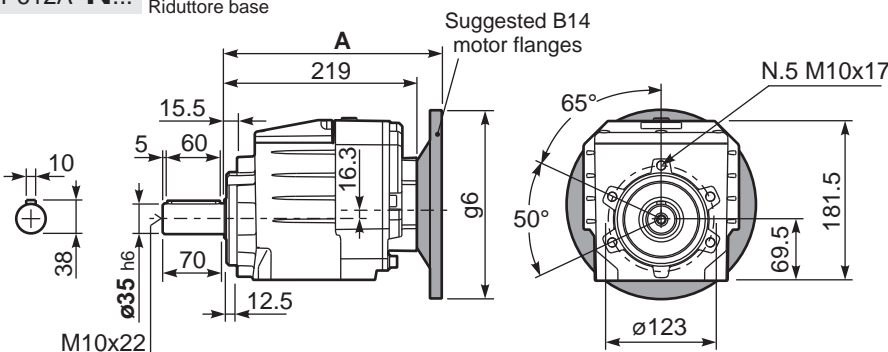

R612A-**N**... Input Shaft
Albero in entrata

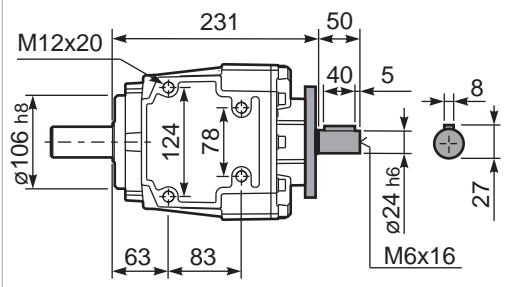

B5 Motor Flanges	A	C _{max}	g6	k1	kit code	k1 with KC50.9.011	B14 Motor Flanges	A	C _{max}	g6	k1	kit code	k1 with KC50.9.011
71 B5	237.5	251.3	160	240	K023.4.041	246	80 B14	239.5	231.3	120	242	K085.4.046	248
80/90 B5	239.5	271.3	200	242	K023.4.042	248	90 B14	239.5	241.3	140	242	K085.4.045	248
100/112 B5	248.5	296.3	250	251	K023.4.043	257	100/112 B14	248.5	251.3	160	251	K085.4.047	257
132 B5	269.5	321.3	300	269	KC51.4.043	275	132 B14	269.5	271.3	200	269	KC51.4.041	275