



QUICK SELECTION / Selezione veloce

input speed (n₁) = 1400 min⁻¹

Output Speed n ₂ [min ⁻¹]	Ratio i	Motor power P _{1M} [kW]	Output torque M _{2M} [Nm]	Service factor f.s.	Nominal power P _{1R} [kW]	Nominal torque M _{2R} [Nm]	Available B5 motor flanges					Available B14 motor flanges				Output Shaft		Ratios code
							-C	-D	-E	-F	-G	-R	-T	-U	-V			
							71	80	90	100* 112	132*	80	90	100 112	132			
388	3.61	4	93	1.6	6.3	150	B									3018		01
331	4.23	4	108	1.6	6.1	170	B									3016		02
279	5.01	4	129	1.6	6.1	200	B									3014		03
231	6.07	4	156	1.6	6.3	250	B									3012		04
206	6.81	4	175	1.6	6.2	277	B									2018		05
176	7.96	4	204	1.5	5.8	300	B									2016	standard ø30	06
148	9.45	4	242	1.3	4.9	304	B									2014		07
122	11.43	4	293	1.0	4.0	300	B									2012		08
99	14.21	3	274	1.0	2.8	265	B									2010	ø24	09
84	16.62	3	321	0.9	2.8	304	B									1314	ø25	10
70	20.10	2.2	286	1.0	2.3	300	B									1312	ø28	11
56	24.98	1.85	302	0.9	1.6	265	B									1310	ø35	12
47.6	29.41	1.5	288	1.1	1.6	304	B									814	On request	13
39.3	35.58	1.5	349	0.9	1.3	300	B									812		14
34.6	40.50	1.1	290	1.0	1.1	290	B									614		15
31.7	44.23	1.1	316	0.8	0.92	265	B									810		16
28.6	49.00	0.75	240	1.2	0.93	300	B									612		17
23.0	60.90	0.75	299	0.9	0.66	265	B									610		18

The dynamic efficiency is **0.96** for all ratios *Nel montaggio P la flangia può superare l'ingombro massimo dei piedi. Eventualmente utilizzare la flangia B14
* In the P mounting the B5 motor flange can exceed the foot maximum dimensions. Possibly use the flange B14

- Motor Flanges Available** Flange Motore Disponibili
- B) Supplied with Reduction Bushing** Fornito con Bussola di Riduzione
- B) Available on Request without reduction bushing** Disponibile a Richiesta senza Bussola di Riduzione
- C) Motor Flange Holes Position** Posizione Fori Flangia Motore

EN Unit **452A** is supplied with synthetic oil for lifetime lubrication, no maintenance is necessary. See table 1 for lubrication and recommended quantity. In table 2 please see possible radial loads and axial loads on the gearbox.

I Il riduttore **452A** viene fornito completo di olio sintetico per la lubrificazione permanente e non necessita di alcuna manutenzione. Vedi tab.1 per oli e quantità consigliati. In tab.2 sono presenti i carichi radiali e assiali applicabili al riduttore.

D Das Getriebe **452A** ist mit synthetischem Öl gefüllt und ist lebensdauer geschmiert. In Tabelle 1 ist die Schmiermenge und das empfohlene Schmiermittel angegeben. In Tabelle 2 sind die zulässigen Radial - und Axialbelastungen des Getriebes aufgeführt.

F Le réducteur **452A** est fourni complet avec de l'huile synthétique pour la lubrification permanente et ne nécessite aucun entretien. Voir tableau 1 concernant les huiles et les quantités conseillées. Les charges radiales et axiales applicables au réducteur sont précisées dans le tableau 2.

E El reductor tamaño **452A** se suministra, lubricado de por vida con aceite sintético y no requieren mantenimiento alguna. Ver tabla 1, para cantidades y aceites recomendados. En la tabla 2, se encuentran las cargas radiales y axiales admitidas por el reductor.

Standard supplied	For these mounting position specify in the order or add oil					
	Per queste posizioni specificare in fase d'ordine o aggiungere olio					
B3	B6	B7	B8	V5	V6	V8
0.31 LT	0.31 LT	0.31 LT	0.31 LT	0.31 LT	0.31 LT	Ask
SHELL Omala S4 WE 320			AGIP Telium VSF 320			

For all details on lubrication and plugs check our website **tab. 1**
Per maggiori dettagli su lubrificazione e tappi olio vedi il nostro sito web

RADIAL AND AXIAL LOADS

Output shaft / Albero di uscita

$F_{eq} = FR \cdot \frac{51}{X+21}$

n ₂	FA	FR	n ₂	FA	FR	n ₂	FA	FR
300	415	2070	140	540	2700	70	700	3510
250	430	2160	120	560	2790	40	810	4050
200	470	2340	85	630	3150	15	900	4500

Input shaft / Albero in entrata

n ₁	FA	FR
1400	400	2000
900	440	2200
500	440	2200

tab. 2

P452A-B1...

With feet
Con piedini

Gearbox weight
peso riduttore

With flange **8.7 kg**
With feet **8.9 Kg**

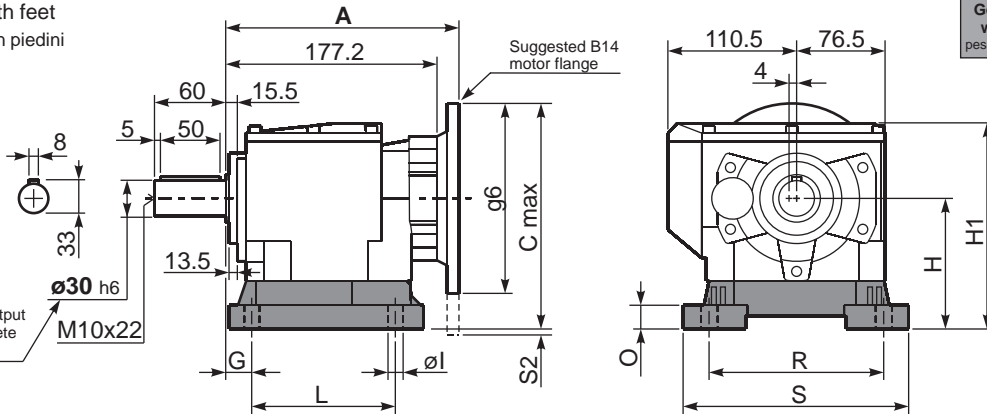

Feet / piedini

Feet Code	Market reference	G	H	R	L	S	H1	O	øl	S2 only with motor flange	B5 max. Flange	kit code
B3	312/3	18	110	160	130	190	173	20	11	15 100/112B5 40 132B5	-	KC50.9.024
B4	30/35	20	130	180	149.5	216	193	18	14	20 132B5	-	KC60.9.024
S4	47-57	30	115	135	165	170	178	24	13.5	-	80/90B5	KC50.9.022
H3	023-233	30	130	135	135	185	193	25	14	20 132B5	-	KC50.9.025
M2	52/3	30	110	135±150	100	190	173	18	11	15 100/112B5 40 132B5	-	KC50.9.023

Other feet are available, see our web site
Sono disponibili altri piedini, consulta il nostro sito web

A see on page bottom

Most popular types
Tipi più diffusi

P452A-F...

Output flanges
flange di uscita

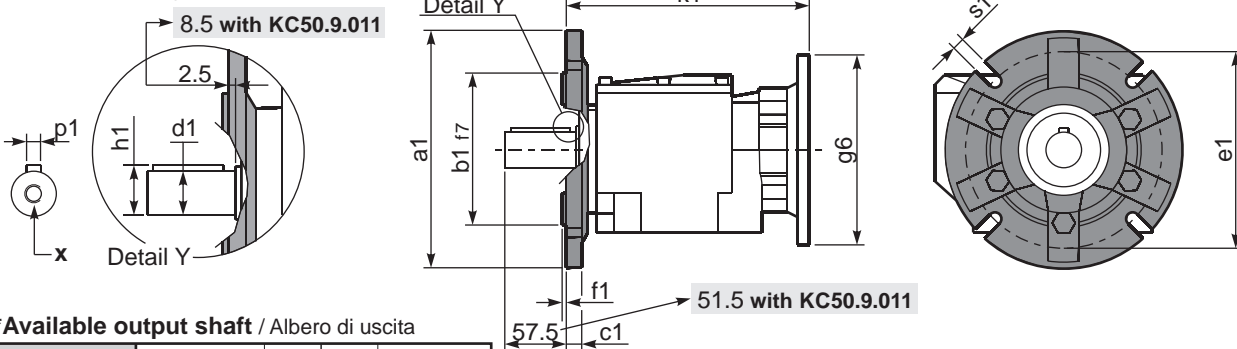

*Available output shaft / Albero di uscita

	Shaft - d1	p1	h1	x
Standard	ø 30x60	8	33	M10x22
On request A richiesta	ø 24x50	8	27	M8x19
	ø 25x50	8	28	M8x19
	ø 28x60	8	31	M8x19
	ø 35x60	10	38	M10x22

Available output flanges / flange di uscita

a1 ø	b1	c1	e1	f1	s1	kit code
160	110	14	130	3.5	11	KC50.9.011
200	130	13	165	3.5	11	KC50.9.012
250	180	15.5	215	4	14	KC50.9.013

With flange and feet only on request.
Ask for compatibility

P452A-N...

Basic gearbox
Riduttore base

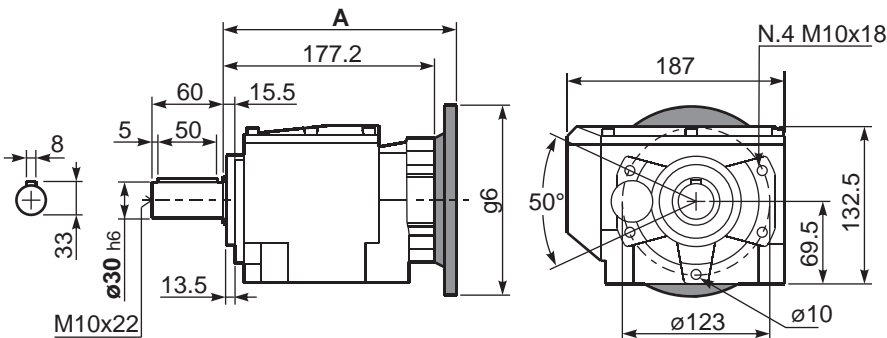

R452A-N...

Input Shaft
Albero in entrata

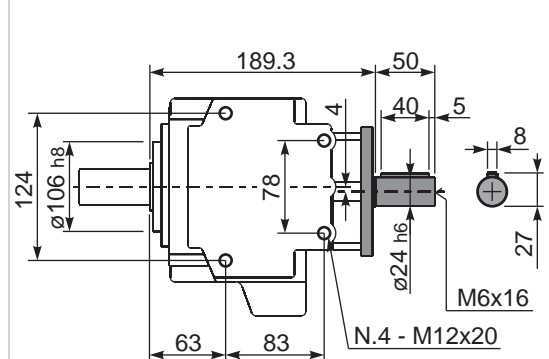

B5 Motor Flanges	A	C _{max}	g6	k1	kit code	k1 with KC50.9.011	B14 Motor Flanges	A	C _{max}	g6	k1	kit code	k1 with KC50.9.011
71 B5	195.7	222	160	198.2	K023.4.041	204.2	80 B14	197.7	202	120	200.2	K085.4.046	206.2
80/90 B5	197.7	242	200	200.2	K023.4.042	206.2	90 B14	197.7	212	140	200.2	K085.4.045	206.2
100/112 B5	206.7	267	250	209.2	K023.4.043	215.2	100/112 B14	206.7	222	160	209.2	K085.4.047	215.2
132 B5	227.7	292	300	227.2	KC51.4.043	233.2	132 B14	227.7	242	200	227.2	KC51.4.041	233.2