

# 60 SERIES BLDC Motor



## GENERAL SPECIFICATION

Winding type: Star
Hall effect angle: 120 degree electrical angle
Shaft run out: 0.025mm
Insulation Class: Class B
Dielectric strength:500VDC for one minute
Ambient temperature: -20—+40℃

## WIRE DIAGRAM

Lead No.	Lead Color	Lead Gauge	Function
1	RED	18AWG UL1569	Phase U
2	YEL		Phase V
3	BLA		Phase W
4	RED	26AWG UL1569	+5V
5	BLU		Hall A
5	GRE		Hall B
7	WHI		Hall C
8	BLA		GND

## ELECTRICAL SPECIFICATION

Model		60DM75-3630	60DM95-3630	60DM115-3630
Voltage	V	36		
Number of poles		8		
Rated power	W	80	160	230
No load speed	rpm	4100	4100	4100
Rated torque	Nm	0.25	0.5	0.75
Rated Speed	rpm	3000	3000	3000
Rated Current	A	3	6	9
Torque(max)	Nm	0.75	1.5	2
Back-EMF constant	V/Krpm	6.2	6.5	6.5
Torque Constant	Nm/A	0.043	0.045	0.041
Resistance	ohm	0.59	0.26	0.2
Weight	Kg	0.9	1.2	1.6
Length	mm	75	95	115

## DIMENSIONS

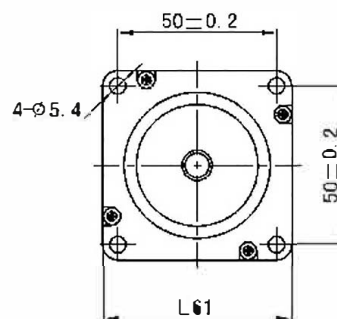
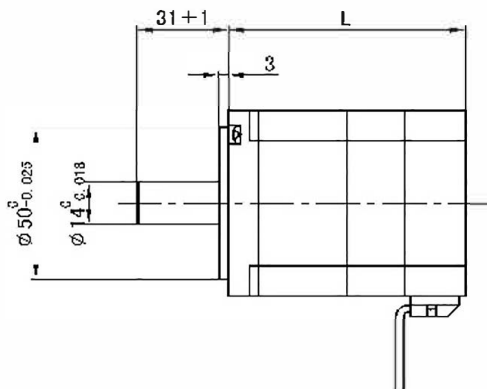

Connection mode

